



## Measurement of Odor Intensity by an Electronic Nose

Guillaume Hudon , Christophe Guy & Jacques Hermia

To cite this article: Guillaume Hudon , Christophe Guy & Jacques Hermia (2000) Measurement of Odor Intensity by an Electronic Nose, Journal of the Air & Waste Management Association, 50:10, 1750-1758, DOI: [10.1080/10473289.2000.10464202](https://doi.org/10.1080/10473289.2000.10464202)

To link to this article: <https://doi.org/10.1080/10473289.2000.10464202>



Published online: 27 Dec 2011.



[Submit your article to this journal](#)



Article views: 495



[View related articles](#)



Citing articles: 26 [View citing articles](#)

# Measurement of Odor Intensity by an Electronic Nose

**Guillaume Hudon and Christophe Guy**

*Department of Chemical Engineering, Ecole Polytechnique, Montréal, Québec, Canada*

**Jacques Hermia**

*Unité des Procédés, Université Catholique de Louvain, Louvain-la-Neuve, Belgium*

## ABSTRACT

The possibility of using electronic noses (ENs) to measure odor intensity was investigated in this study. Two commercially available ENs, an Aromascan A32S with conducting polymer sensors and an Alpha M.O.S. Fox 3000 with metal oxide sensors, as well as an experimental EN made of Taguchi-type tin oxide sensors, were used in the experiments. Odor intensity measurement by sensory analysis and EN sensor response were obtained for samples of odorous compounds (*n*-butanol, CH<sub>3</sub>COCH<sub>3</sub>, and C<sub>2</sub>H<sub>5</sub>SH) and for binary mixtures of odorous compounds (*n*-butanol and CH<sub>3</sub>COCH<sub>3</sub>). Linear regression analysis and artificial neural networks (ANN) were used to establish a relationship between odor intensity and EN sensor responses.

The results suggest that large differences in sensor response to samples of equivalent odor intensity exist and that sensitivity to odorous compounds varies according to the type of sensors. A linear relationship between odor intensity and averaged sensor response was found to be appropriate for the EN based on conducting polymer sensors with a correlation coefficient (*r*) of 0.94 between calculated and measured odor intensity. However, the linear regression approach was shown to be inadequate for both ENs, which included metal oxide-type sensors. Very strong correlation (*r* = 0.99) between measured odor intensity

and calculated odor intensity using the ANN developed were obtained for both commercial ENs. A weaker correlation (*r* = 0.84) was found for the experimental instrument, suggesting an insufficient number of sensors and/or not enough diversity in sensor responses. The results demonstrated the ability of ENs to measure odor intensity associated with simple mixtures of odorous compounds and suggest that ANN are appropriate to model the relationship between odor intensity measurement and EN sensor response.

## INTRODUCTION

Among environmental pollution types, odor pollution has become one of the most significant issues throughout the developed world. In the United States, complaints of odor pollution account for more than 50% of all complaints to air pollution regulatory agencies,<sup>1</sup> while in Japan, pollution by offensive odors ranks second in terms of number of complaints filed with authorities, following noise pollution.<sup>2</sup> In European countries, large proportions of the population (13–20%) are reported to be annoyed by environmental odors.<sup>3,4</sup> These statistics illustrate the importance of environmental pollution due to odorous emissions and explain the increased tendencies toward regulating odor emissions<sup>5,6</sup> and developing new odor abatement techniques.<sup>7</sup> To evaluate the efficiency of an odor abatement treatment or to determine whether an odorous effluent respects a definite regulation, odors must be adequately quantified. However, because of its subjective nature, the measurement of an odor is not a straightforward task.<sup>8</sup>

At the present time, two approaches are being used for the measurement of odor: analytical techniques and sensory techniques.<sup>9</sup> Analytical techniques, such as gas chromatography associated to mass spectrometry, aim to characterize the nature and concentration of compounds present in odorous mixtures. Results of such analysis can then be compared to olfactory threshold data in order to determine which of the components are present in

## IMPLICATIONS

Odor pollution is a significant issue throughout the developed world, and several legislative bodies have regulated or are in the process of regulating odorous emissions in the environment. The measurement of an odor is not an easy task, and existing methods suffer from major drawbacks. It thus appears that there is a real need for the development of new reliable odor measurement techniques. This paper investigates the possibility of using ENs to measure odor intensity. The proposed procedure, which comprises training ANN to predict odor intensity based on EN sensor response, was applied with success for simple mixtures of odorous compounds.

suprathreshold concentrations. However, this type of analysis is limited because it does not take into account the physiological interactions that arise in a complex odor mixture,<sup>10</sup> hence not providing a real quantification of the odor. Sensory techniques fulfill that lack by using human noses to perform the measurement. Odors can be quantified by a panel of people in terms of perceived intensity or in terms of odor concentration.<sup>11</sup> In the former case, the panelists must assign a value to the perceived odor intensity based on a given referencing scale,<sup>12</sup> while in the latter case, the odor concentration is defined as the number of dilutions at which 50% of the panel members can just detect the odor.<sup>13</sup> Although giving representative measurements, sensory techniques also have major drawbacks: they are time-consuming and expensive,<sup>14</sup> and they cannot be used for continuous monitoring. Thus, there is apparently a real need for the development of reliable odor assessment techniques that could be representative of the odor strength and at the same time suitable for on-line monitoring.

An electronic nose (EN) is an instrument that comprises an array of electronic chemical sensors with partial specificity and an appropriate pattern-recognition system capable of recognizing simple or complex odors.<sup>15</sup> Different types of sensor technologies, such as metal oxide sensors, conducting polymer sensors, and piezoelectric sensors, are used in commercial ENs, and the number of sensors can vary between 1 and 40.<sup>16</sup> Following their exposure to a given odor, sensor responses form a particular profile that can be analyzed with pattern-recognition techniques. Because EN sensors are sensitive to volatile compounds, not just odors, this calibration step is of critical importance. The main advantage of an EN is that once calibrated, it can be used to perform odor assessment on a continuous basis at a minimal cost. ENs are presently being used mainly in quality control applications, particularly in the food and beverage industry.<sup>15,17</sup> Although several authors have identified environmental odor monitoring as a potential application,<sup>15,16,18</sup> very few studies have been conducted to investigate the possibility of using ENs for odor strength measurement. While showing very promising results, the studies published so far were focused on specific odor sources, such as odors from livestock wastes<sup>13,19,20</sup> and odors from sewage treatment works,<sup>14</sup> that are inherently characterized by high variability. In order to assess the possibility of using ENs for odor quantification in a more systematic way, research needs to be conducted using odor samples of controlled composition.

The objective of this study was to demonstrate that, once calibrated against sensory analysis, ENs can be used to quantify odor intensity associated with simple mixtures of odorous compounds. Three ENs (two commercially

available instruments and an experimental system) based on two different sensor technologies (conducting polymers and metal oxide sensors) were used in the study. Three common odorous substances—CH<sub>3</sub>COCH<sub>3</sub>, *n*-butanol, and C<sub>2</sub>H<sub>5</sub>SH—were selected to constitute the synthetic samples used in the experiments.

## EXPERIMENTAL METHODS

### Odor Sample Preparation

CH<sub>3</sub>COCH<sub>3</sub>, *n*-butanol, and C<sub>2</sub>H<sub>5</sub>SH were chosen to represent substances with different odor characteristics. C<sub>2</sub>H<sub>5</sub>SH is an extremely malodorous substance with a rotten cabbage odor and can be detected at very low concentrations (0.098–3 ppbv).<sup>21</sup> CH<sub>3</sub>COCH<sub>3</sub> is also a malodorous substance and may be perceived as pungent. Among the three compounds used in the experiments, CH<sub>3</sub>COCH<sub>3</sub> has the highest detection threshold (3.6–653 ppmv).<sup>21</sup> With its sweet alcohol odor, *n*-butanol can be considered as pleasant. It is commonly used in olfactory experiments and its detection threshold (0.12–11 ppmv)<sup>21</sup> lies between those of CH<sub>3</sub>COCH<sub>3</sub> and C<sub>2</sub>H<sub>5</sub>SH. The three substances used were of the highest purity available.

The odor samples were prepared by diluting the odorous compounds in distilled water. The samples were maintained at 22.5 °C in order to ensure a constant vapor–liquid equilibrium. For each odorous compound, three concentrations corresponding to three levels of perceived odor intensity were determined in a preliminary experiment. The concentrations (in the liquid and vapor phases) and intensity levels are given in Table 1 (details on the intensity measurement procedure are provided in the following section). As an indication, odors corresponding to level 1 are just perceptible, while odors associated with levels 2 and 3 are, respectively, slight and moderate.

### Sensory Analysis

The sensory analysis consisted of perceived odor intensity measurement. The analysis was performed using an *n*-butanol static reference scale such as described in ASTM Standard E-544.<sup>22</sup> It comprised eight concentrations of *n*-butanol in water (0; 46; 278; 680; 1667; 4082; 10,000; and 24,995 ppmv) maintained at a constant temperature of 22.5 °C [mean = 22.4 °C, SD (standard deviation) = 0.4 °C]. Five panelists were asked to evaluate each odor sample twice by locating the position on the scale that best matched its odor intensity. Since a concentration of *n*-butanol (*C*) is not in itself a direct measure of perceived odor intensity (*I*), the reference scale had to be translated to a magnitude estimate scale as described by Moskowitz et al.<sup>23</sup> Equation 1

$$I = 1.175C^{0.70} \quad (1)$$

**Table 1.** Concentration and perceived odor intensity levels for the odorous compounds used in the study.

Level	<i>n</i> -Butanol			CH <sub>3</sub> COCH <sub>3</sub>			C <sub>2</sub> H <sub>5</sub> SH		
	Conc. (ppmv)		Odor Intensity	Conc. (ppmv)		Odor Intensity	Conc. (ppbv)		Odor Intensity
	Liquid	Vapor <sup>a</sup>		Liquid	Vapor <sup>a</sup>		Liquid	Vapor <sup>a</sup>	
1	46.0	0.7	0.86	374.9	141.3	1.81	0.4	0.1	1.24
2	680.0	9.5	6.09	2493.8	939.3	8.06	2.3	0.4	6.81
3	4081.8	57.1	18.84	9901.0	3715.4	25.49	9.7	1.5	15.05

<sup>a</sup>Vapor phase in equilibrium with the liquid phase at 22.5 °C.

was developed for that purpose. Once the conversion was made, the perceived odor intensity of a given sample was calculated as the arithmetic mean of all values obtained for that sample.

### Electronic Nose Analysis

Three ENs—two commercially available instruments and an experimental system—were used in the experiments. One of the commercial ENs used was an Aromascan A32S (Aromascan plc). This instrument incorporated an array of 32 sensors made of conducting polymers. The other commercial EN was an Alpha M.O.S. Fox 3000 system (Alpha M.O.S. SA), which included 12 metal oxide-type sensors. The third EN was developed at Ecole Polytechnique de Montréal using six Taguchi-type tin oxide sensors manufactured by Figaro Engineering Inc. (models TGS 800, TGS 822, TGS 825, TGS 826, TGS 880, and TGS 882). The sensors were mounted in a test box SR3 (Figaro Engineering) especially designed for the testing of those sensors. It should be noted that the software packages for data analysis included in both commercial ENs were not used in the present study.

A dynamic sampling procedure for odor presentation to the sensors was used with the three instruments. The odor sample to be analyzed was first placed in a controlled temperature environment (22.5 °C ± 0.1 °C for the Aromascan and the Alpha M.O.S instruments and 25 °C ± 0.5 °C for the experimental EN) until thermal equilibrium was reached. A stream of filtered air was then bubbled through the liquid sample prior to being injected in the chamber containing the sensors. The response of each sensor was recorded as  $\Delta R/R_0$ , where  $\Delta R$  is the change in resistance and  $R_0$  is the base resistance of the sensor. The base resistance corresponded to the response of the sensor in the presence of reference air. For the three instruments, the reference air consisted of filtered ambient air. For the Aromascan and Alpha M.O.S. instruments, the relative humidity of the reference air was set at 40% (at 30 °C), while for the experimental EN, no humidity control was completed. With the three instruments, each sample was analyzed twice, and the average response of

the duplicate was taken as the EN odor profile for that given sample.

### Data Analysis

Two types of data analysis were performed to try to model the relationship between EN sensor response and odor intensity measured by sensory analysis. In the first analysis, linear regressions of averaged sensor response against odor intensity were calculated for the three EN instruments. The least-squares method was used in the calculations. The second type of analysis consisted of training artificial neural networks (ANN) to predict odor intensity measurement based on EN sensor response (Figure 1). Multilayer perceptron networks comprising two layers of neurons were used. Six units were used on the hidden layer and one on the output layer. The Levenberg-Marquardt algorithm,<sup>24</sup> an advanced back propagation learning rule, was used to train the ANN in a supervised manner. For each simulation, the data set was divided at random into two subsets: the training set (80% of the samples) and the validation set (remaining 20%). The training set was used in the network weights adjustment procedure (learning phase), while the validation set was required to assess the network generalization capacity after it had been trained (validation phase). The ANN simulations were performed using MATLAB and MATLAB Neural Network Toolbox mathematical packages (The MathWorks, Inc.).

## RESULTS AND DISCUSSION

### Electronic Nose Responses to the Levels of Odor Intensity for Each Odorous Compound

The first series of experiments performed consisted of obtaining the EN sensor response to the three levels of odor intensity for *n*-butanol, CH<sub>3</sub>COCH<sub>3</sub>, and C<sub>2</sub>H<sub>5</sub>SH (see Table 1). The odor profiles thus obtained are shown in Figure 2 (Aromascan EN), Figure 3 (Alpha M.O.S. EN), and Figure 4 (experimental EN). The level 0 included on the plots corresponds to the EN sensor response when exposed to a blank sample (distilled water). The first finding, which is evident in Figures 2–4, is the inability of any of the ENs

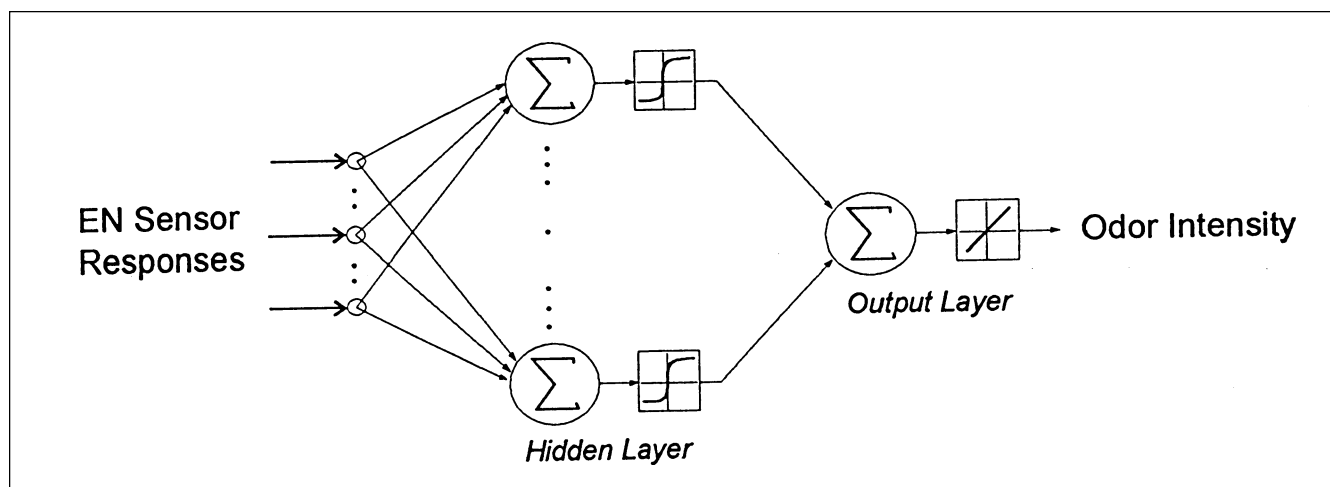

**Figure 1.** Neural network structure. The inputs are the EN sensor responses and the output is the odor intensity.

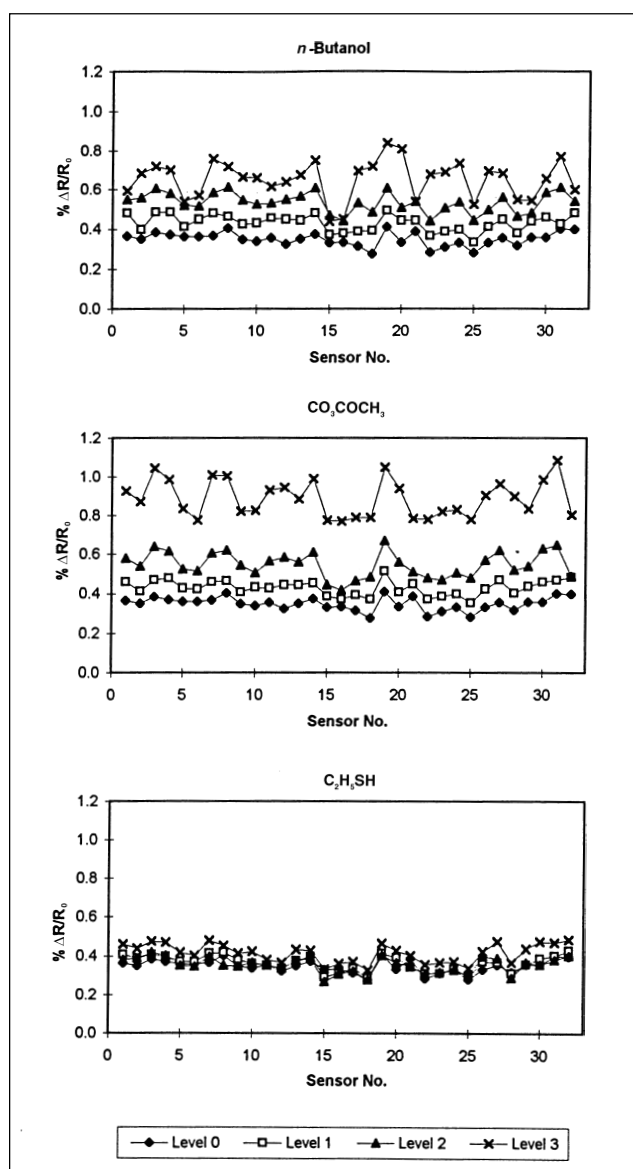
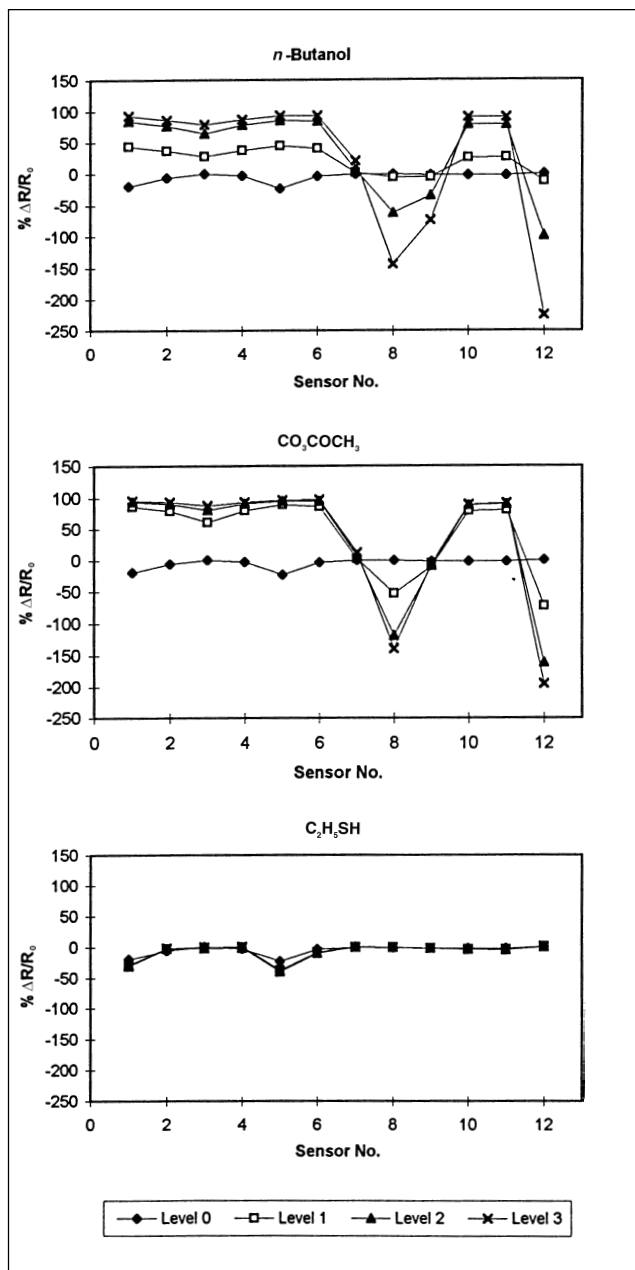

**Figure 2.** Odor profiles obtained for the three odorous compounds with the Aromascan EN.

used to clearly distinguish between the different levels of intensity for  $C_2H_5SH$ . In all cases, the sensor responses obtained for  $C_2H_5SH$  are very weak and can be explained by the low concentrations involved. The Alpha M.O.S. and experimental instruments could not clearly differentiate the levels of intensity for  $CH_3COCH_3$  for an opposite reason: the sensors were too sensitive. It should be noted that these two instruments included metal oxide-type sensors and that this high sensitivity to  $CH_3COCH_3$  was not encountered with the Aromascan EN, whose sensors were made of conducting polymer. Therefore, *n*-butanol was the only compound for which the three levels of odor intensity could easily be discriminated by the three instruments.

Since the EN responses to  $C_2H_5SH$  were not satisfying, it was decided not to include this compound in the mixtures in subsequent experiments. Furthermore, to obtain a better discrimination for the odor intensity levels associated with  $CH_3COCH_3$ , the samples to be analyzed by the Alpha M.O.S. and experimental ENs had to be diluted. Dilution factors of 10 and 5 were, respectively, applied to all samples analyzed by the Alpha M.O.S. and experimental instruments (based on the concentrations presented in Table 1). The new odor profiles thus obtained are shown in Figures 5 and 6. It is clear from these plots that the ability of both instruments to distinguish between each level of odor intensity after diluting the samples becomes much better for  $CH_3COCH_3$ , while remaining perfectly acceptable for *n*-butanol.

Two facts were evident in this first series of experiments. First, it was shown that EN sensor response to samples of equivalent odor intensity can be very different from one odorous compound to another. Therefore, if an EN were to be used to assess odor intensity in a particular application, the first step would be to make sure its sensors could respond to all the odorous compounds



**Figure 3.** Odor profiles obtained for the three odorous compounds with the Alpha M.O.S. EN.

potentially present. Diluting the samples as was done in this study for the Alpha M.O.S. and experimental ENs is a simple option to consider when the sensors responses are too large. On the other hand, when the opposite situation is encountered (weak responses), as observed for  $C_2H_5SH$  in the experiments, the only option left is to use a more sensitive sensor type. The second fact that is evident from the first series of experiments is the significant differences in sensitivity among sensor technologies. In this manner, it was observed that the metal oxide sensors used in the study were much more sensitive to  $CH_3COCH_3$  and  $n$ -butanol than the conducting polymer sensors were. Therefore, it is justified to state that in order to maximize

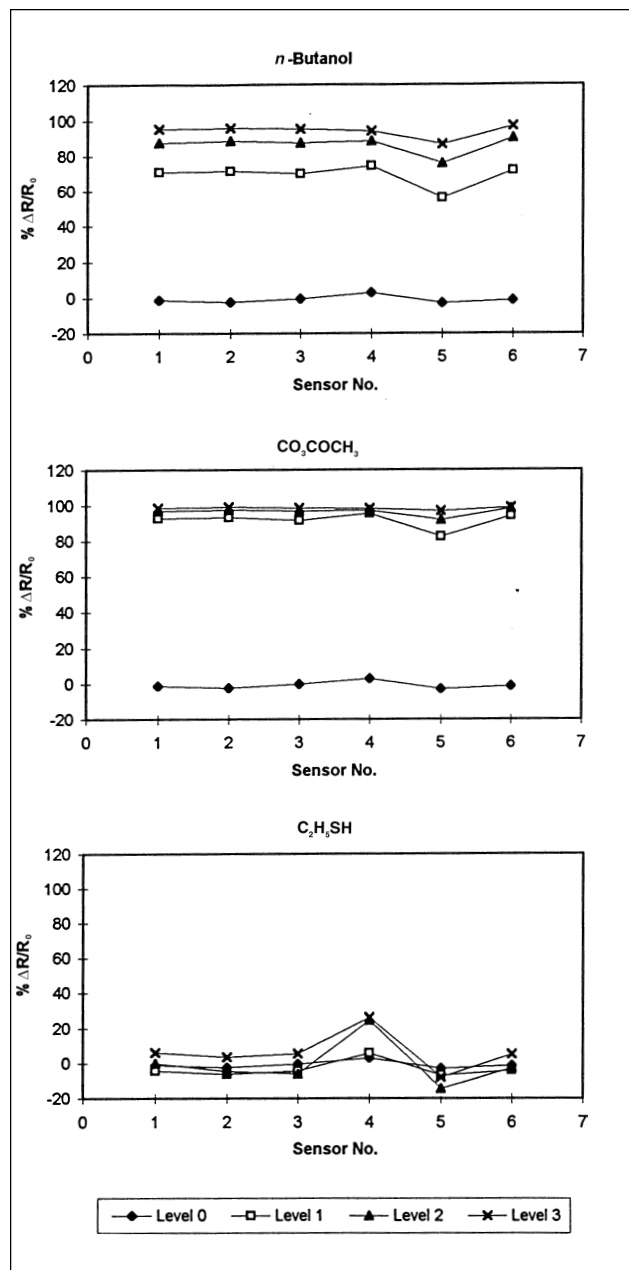
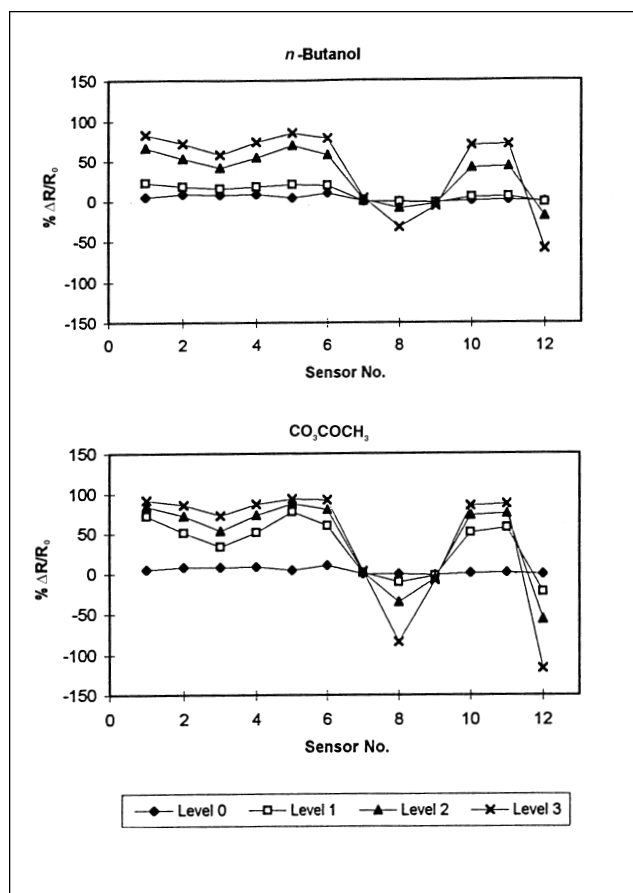

**Figure 4.** Odor profiles obtained for the three odorous compounds with the experimental EN.

its performance, an EN intended for use as an odor intensity measurement should be a hybrid instrument comprising sensors of different technologies.

### Relationship between EN Response and Odor Intensity for Binary Mixtures of $n$ -Butanol and $CH_3COCH_3$

The nine possible binary mixtures that can be constituted from the three levels of concentrations of  $n$ -butanol and  $CH_3COCH_3$  were prepared and analyzed by the three EN instruments. The EN odor profiles acquired were added to the previously obtained odor profiles for  $n$ -butanol and  $CH_3COCH_3$  to form a data set of 16 experimental samples



**Figure 5.** Odor profiles obtained for the three odorous compounds with the Alpha M.O.S. EN after dilution.

(nine binary mixtures, three levels for *n*-butanol, three levels for  $\text{CH}_3\text{COCH}_3$ , and a blank). The relationship between the responses obtained by the EN for the samples and their corresponding odor intensity was investigated using two approaches: linear regression and ANN modeling.

**Linear Regression Analysis.** A very simple way of expressing the relationship between odor intensity such as measured by sensory analysis and EN response is to calculate a linear regression between the odor intensity ( $I$ ) and the averaged sensor response to the odor samples ( $\bar{r}$ ). Since some values were negative,  $\bar{r}$  was calculated using the absolute values of  $\Delta R/R_0$ . The following equations were obtained for the Aromascan (eq 2), Alpha M.O.S. (eq 3), and experimental (eq 4) EN instruments:

$$I = 39\bar{r} - 14 \quad (2)$$

$$I = 0.36\bar{r} - 7.4 \quad (3)$$

$$I = 0.24\bar{r} - 5.4 \quad (4)$$

The plot in Figure 7a shows that the linear regression

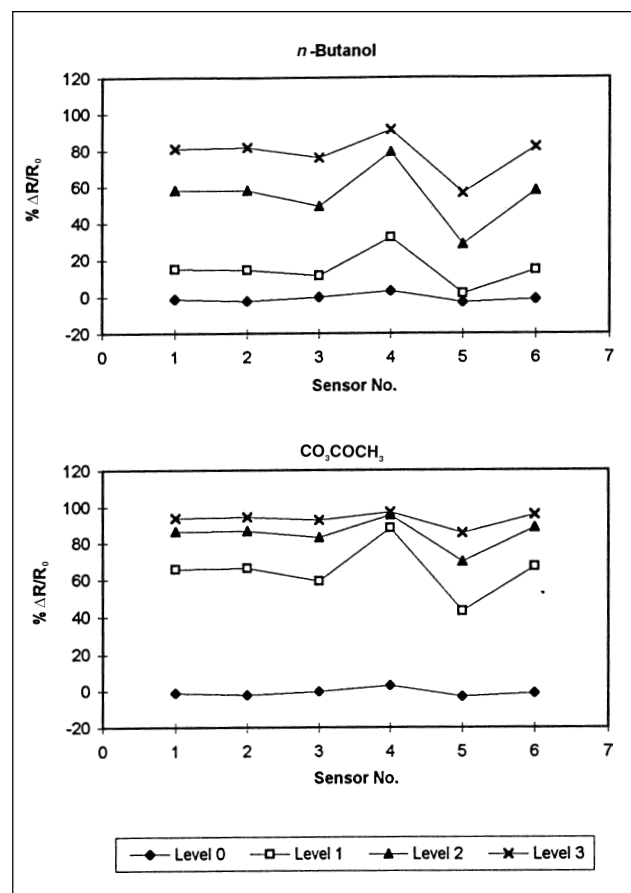

**Figure 6.** Odor profiles obtained for the three odorous compounds with the experimental EN after dilution.

approach gives fairly good results for the measurements made with the Aromascan instrument. This is confirmed by the correlation coefficient of 0.94 obtained between the calculated odor intensity using the derived linear equation and the measured odor intensity. This finding is in agreement with those of Persaud et al.<sup>19</sup> and Misselbrook et al.,<sup>20</sup> who showed that a linear relationship can represent the relationship between averaged EN response and odor concentration when ENs with conducting polymer sensors are used. It is also worth noting that the linear relationship found is not a consequence of the large number of sensors in the Aromascan EN. Indeed, the linearity still stands if the responses of only 6 or 12 sensors, chosen at random among the 32 sensors, are used in the calculations.

The linear regression analysis did not give similar results for the two other instruments used. It was found that a linear regression was inadequate to represent the relationship between EN response and odor intensity for both the Alpha M.O.S. (Figure 7b) and experimental ENs (Figure 7c). In both cases, the calculated odor intensity using the linear regression equation underestimates the measured value at low and high odor intensity, while overestimating it at intermediate odor intensity (Figures

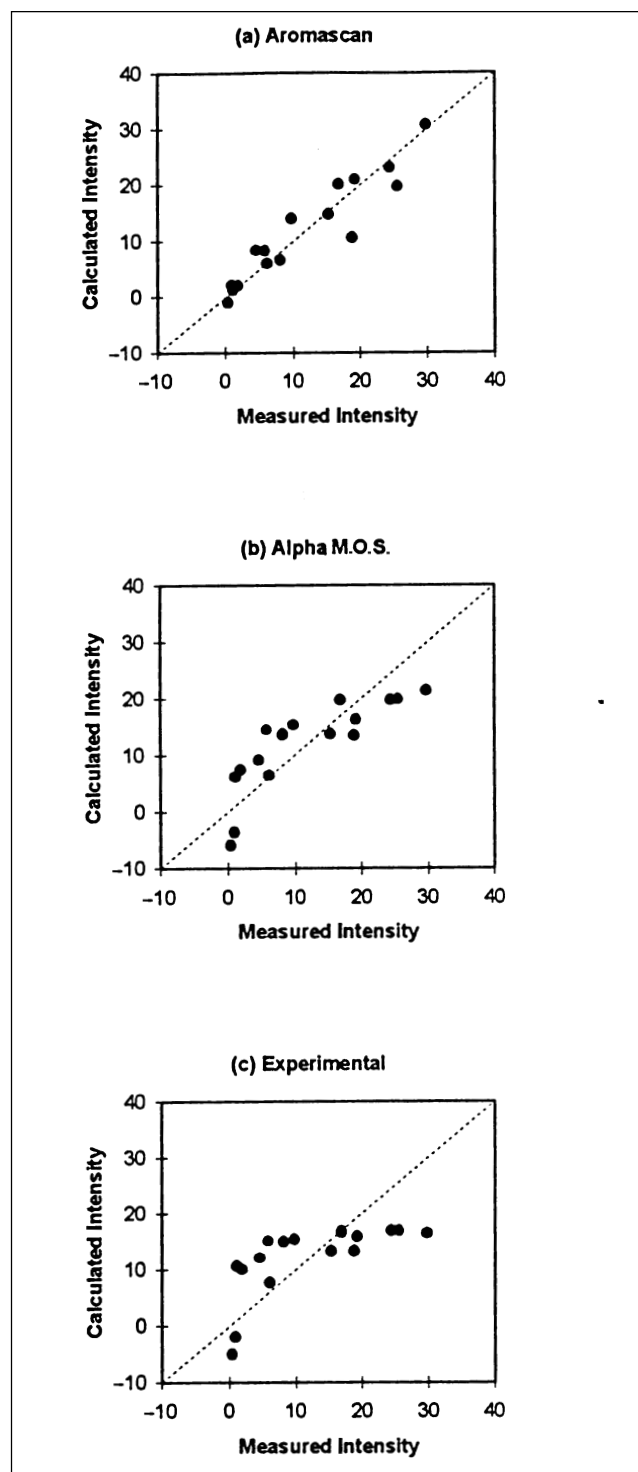

**Figure 7.** Odor intensity calculated using the linear regression equation derived from the averaged EN sensor response plotted against measured odor intensity by sensory analysis. Data for (a) Aromascan, (b) Alpha M.O.S., and (c) experimental instruments.

7b and 7c). Since these two ENs are based on metal oxide-type sensors, it is reasonable to believe that this finding is characteristic of this sensor technology.

Although acceptable results were obtained in the case of the Aromascan EN, the overall results suggest that the

linear regression approach is not appropriate to represent the relationship between EN responses and odor intensity. A large part of the information contained in the sensor response pattern is indeed lost when the averaging operation is performed.

**ANN Modeling.** Unlike the linear regression approach, ANN analysis allows one to take into account the whole pattern of sensor response for each odor sample. Therefore, much better results can be expected. Odor intensities calculated with the ANN developed for each EN are plotted against measured odor intensity in Figure 8. In those plots, filled circles represent data points that were part of the training set and open circles represent data points from the validation set. Very strong correlations between calculated and measured values were obtained for the Aromascan (Figure 8a) and Alpha M.O.S. (Figure 8b) instruments, with a coefficient of correlation of 0.99 in both cases.

It is worth noting that although the Alpha M.O.S. EN (12 sensors) counts almost 3 times fewer sensors than the Aromascan EN does (32 sensors), both instruments gave similar results. A problem often encountered in ANN modeling is overfitting.<sup>24</sup> It results in networks that fit the training data almost perfectly, but have poor predictive capacity. This is clearly not the case here, as shown by the position of the validation data points in Figures 8a and 8b. The networks developed could, therefore, be used with confidence to accurately predict the odor intensity for any mixture of *n*-butanol and  $\text{CH}_3\text{COCH}_3$  based on an odor profile obtained by the Aromascan or Alpha M.O.S. EN.

The results obtained with the experimental EN were not as conclusive. While the trend in the data shown in Figure 8c is still apparent, considerable scatter is observed in the plot. The correlation between calculated and measured odor values is much weaker ( $r = 0.84$ ) for the experimental EN than for the two commercial instruments. Several factors could possibly explain the poorer performance: an insufficient number of sensors, not enough diversity in the sensor responses, or the absence of humidity control.

The potential of an EN to be used as a measuring device for odor intensity was confirmed by the results obtained for the two commercial ENs. The proposed method of analyzing the odor profiles from the sensor responses using ANN worked well in the case of simple binary mixtures of odorous compounds. Because real environmental odors are complex mixtures of odorous compounds, further work is required to confirm that the method can be applied under such conditions. A first aspect that should be investigated in future studies is to determine whether there is enough diversity in existing sensor technologies to allow a proper characterization of environmental odors. Another factor that requires some attention is the number



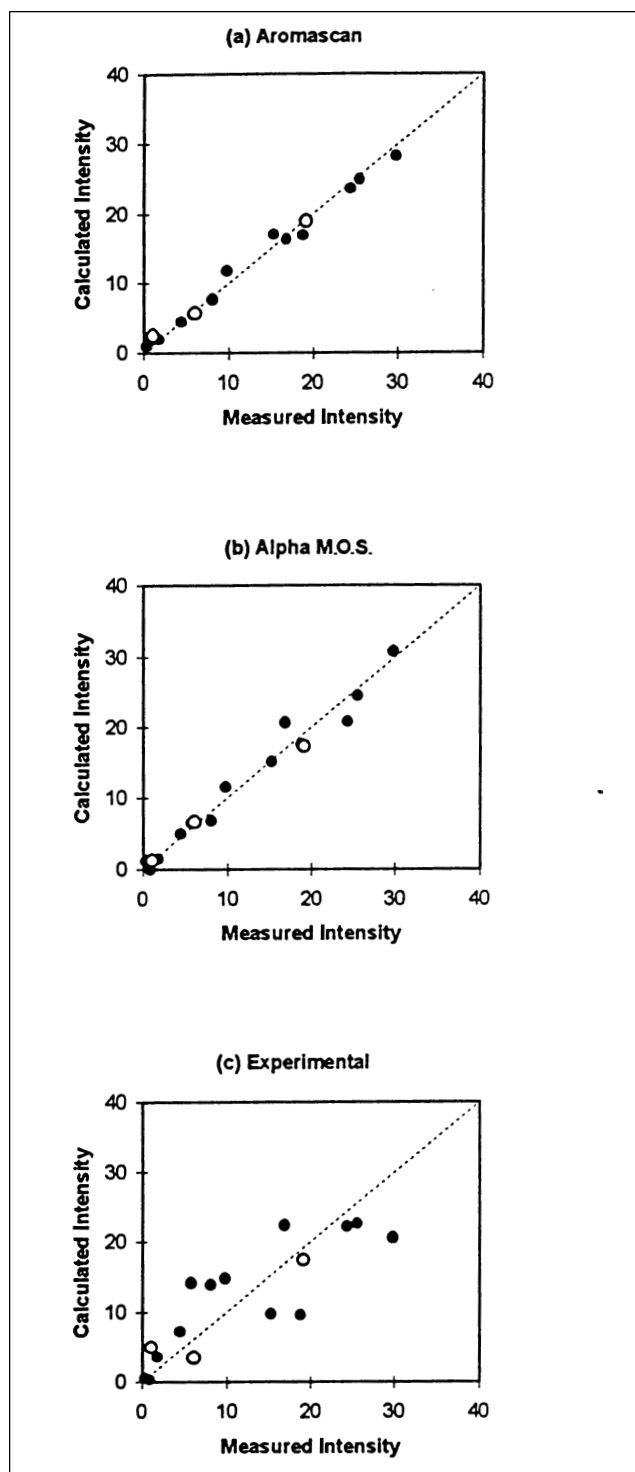

**Figure 8.** Odor intensity calculated using the ANN plotted against measured odor intensity by sensory analysis. The filled circles represent training data points and the open circles represent validation data points. Data for (a) Aromascan, (b) Alpha M.O.S., and (c) experimental instruments.

of data points that are necessary to train the ANN. In the present study, a small number of data points (13) were used to successfully train the networks. However, it would be important to verify the impact of the odor mixture

complexity on the size of the training data set required to ensure effective training. The change of sensitivity of the sensors versus time is a difficulty encountered with ENs<sup>15,16</sup> that should also be addressed in future work. Indeed, the harsh conditions the instrument would be exposed to if used in environmental applications could lead to faster deterioration of the sensors.

A final aspect that must be emphasized is the versatility of the proposed approach. In this study, the odors were quantified in terms of intensity. Nevertheless, it should be noted that this particular type of sensory analysis is not the only way to quantify odors.<sup>25</sup> Correlation between EN sensor response and odor-concentration measurement could be developed. Another interesting development of this work could be an investigation of the hidden layer of the ANN, with a possible self-organization of neurons for quality and intensity purposes. This improvement would allow a classification of the odor, in addition to its quantification.

## CONCLUSIONS

The relationship between EN sensor response and odor intensity was investigated using three EN instruments based on two sensor technologies for three odorous compounds. The main observations that can be drawn from this study are

- (1) EN sensor response to samples of equivalent odor intensity can be very different depending on the nature of the compounds present;
- (2) Significant differences in sensitivity to odorous compounds exist among EN sensor technologies;
- (3) For binary mixtures of odorous compounds, a linear regression between odor intensity and averaged sensor response is appropriate to represent the relationship between odor intensity and EN measurement when conducting polymer sensors are used, but is inadequate for metal oxide sensors; and
- (4) For binary mixtures of odorous compounds, ANN can be trained to accurately predict odor intensity from commercial EN sensor responses.

The following general conclusions may be made from this study:

- (1) In order to use an EN to measure odor intensity associated with mixtures of odorous compounds, its sensors' ability to respond to the compounds potentially present in the mixtures must first be assessed; and
- (2) The use of ANN to model the relationship between odor intensity measurement made by sensory analysis and EN sensor response is very promising and its applicability to environmental odors should, therefore, be investigated in future studies.

## ACKNOWLEDGMENTS

The authors would like to thank Interbrew Belgium, for the loan of an Alpha M.O.S. instrument, and the Québec-Wallonie Cooperation Agency. G. Hudon would also like to thank the Natural Sciences and Engineering Research Council of Canada and the Agence Universitaire de la Francophonie for their financial support.

## REFERENCES

1. O'Brien, M.; Deffee, R.A.; Ostojic, N. In *Odors: Indoor and Environmental Air*; McGinley, C.N., Swanson, J.R., Eds.; Air & Waste Management Association: Pittsburgh, PA, 1996; pp 261-267.
2. Higuchi, T.; Konosuke, N. In *Odors: Indoor and Environmental Air*; McGinley, C.N., Swanson, J.R., Eds.; Air & Waste Management Association: Pittsburgh, PA, 1996; pp 181-192.
3. Walpot, J.I. In *Characterization and Control of Odours and VOC in the Process Industries*; Vigneron, S., Hermia, J., Chaouki, J., Eds.; Elsevier Science: Amsterdam, 1994; pp 119-125.
4. Berglund, B.; Lindvall, T. In *The Nose*; Proctor, D.F., Andersen, I., Eds.; Elsevier Biomedical: Amsterdam, 1982; pp 279-305.
5. Vankeerbergen, A. In *Characterization and Control of Odours and VOC in the Process Industries*; Vigneron, S., Hermia, J., Chaouki, J., Eds.; Elsevier Science: Amsterdam, 1994; pp 49-59.
6. Schulz, T.J.; Van Harreveld, A.P. *Water Sci. Technol.* **1996**, *34* (3-4), 541-547.
7. Caruana, C.M. *Chem. Eng. Prog.* **1998**, *94* (3), 11-14.
8. Le Cloirec, P.; Perrin, M. In *Odeurs et Désodorisation dans l'environnement*; Martin, G., Laffort, P., Eds.; Tec & Doc-Lavoisier: Paris, 1991; pp 247-264.
9. Ostojic, N.; O'Brien, M. In *Odors: Indoor and Environmental Air*; McGinley, C.N., Swanson, J.R., Eds.; Air & Waste Management Association: Pittsburgh, PA, 1996; pp 87-95.
10. Laffort, P. In *Perception of Complex Smells and Tastes*; Laing, D.G., Cain, W.S., McBride, R.L., Ache, B.W., Eds.; Academic: Sydney, 1989; pp 205-223.
11. Cha, S.S. In *Odor and VOC Control Handbook*; Rafson, H.J., Ed.; McGraw-Hill: New York, 1998; pp 4.16-4.32.
12. Cain, W.S.; Moskowitz, H.R. In *Human Responses to Environmental Odors*; Turk, A., Johnston, J.W., Jr., Moulton, D.G., Eds.; Academic: New York, 1974; pp 1-32.
13. Hobbs, P.J.; Misselbrook, B.; Pain, B.F. *J. Agric. Eng. Res.* **1995**, *60*, 137-144.
14. Stuetz, R.M.; Fenner, R.A.; Engin, G. *Water Res.* **1999**, *33* (2), 453-461.
15. Gardner, J.W.; Bartlett, P.N. *Sens. Actuators, B* **1994**, *18-19*, 211-220.
16. Nagle, H.T.; Gutierrez-Osuna, R.; Schiffman, S.S. *IEEE Spectrum*, September 1998, pp 22-34.
17. Strassburger, K.J. *CHEMTECH*, December 1997, pp 18-24.
18. Kress-Rogers, E. In *Handbook of Biosensors and Electronic Noses*; Kress-Rogers, E., Ed.; CRC: Boca Raton, FL, 1996; pp 3-39.
19. Persaud, K.C.; Khaffaf, S.M.; Payne, J.S.; Pisanalli, A.M.; Lee, D.-H.; Byun, H.-G. *Sens. Actuators, B* **1996**, *35-36*, 267-273.
20. Misselbrook, T.H.; Hobbs, P.J.; Persaud, K.C. *J. Agric. Eng. Res.* **1997**, *66*, 213-220.
21. *Odor Thresholds for Chemicals with Established Occupational Health Standards*; American Industrial Hygiene Association: Fairfax, VA, 1989.
22. *Standard Practices for Referencing Suprathreshold Odor Intensity*; ASTM E544-75; American Society for Testing and Materials: Philadelphia, PA, 1998.
23. Moskowitz, H.R.; Dravnieks, A.; Cain, W.S.; Turk, A. *Chem. Senses Flavors* **1974**, *1*, 235-237.
24. Demuth, H.; Beale, M. *Neural Network Toolbox User's Guide*; The MathWorks, Inc.: Natick, MA, 1998.
25. Pagé, T.; Guy, C.; Vigneron S. In *Proceedings of the 4th International Conference on Characterization and Control of Odors and VOCs*; Montréal, Québec, Canada, 1997; pp 167-181.

### About the Authors

Guillaume Hudon is a graduate student in the Chemical Engineering Department at Ecole Polytechnique, Montréal, Québec, Canada. Dr. Christophe Guy (corresponding author) is a professor and head of the Chemical Engineering Department at Ecole Polytechnique. Dr. Jacques Hermia is a professor and head of the Unité des Procédés at the Université Catholique de Louvain in Louvain-la-Neuve, Belgium. Dr. Guy may be reached at phone: 514-340-4711, ext. 4818; fax: 514-340-4159; e-mail: Christophe.Guy@mail.polymtl.ca.