

Odor Pollution in the Environment and the Detection Instrumentation

Arief Sabdo Yuwono¹ and Peter Schulze Lammers²

¹ Dept. of Agricultural Engineering, Bogor Agricultural University (IPB), PO Box 220
Bogor 16002, Indonesia. E-mail: ayuwono@ipb.ac.id

² Dept. of Agricultural Engineering, University of Bonn, Nussallee 5, 53115 Bonn,
Germany. E-mail: lammers@uni-bonn.de

ABSTRACT

Odor or malodor, which refers to unpleasant smells, is nowadays considered an important environmental pollution issue. Odor pollution abatement has involved a number of bodies. A comprehensive description of pollution abatement and the development of the accompanying instrumentation technology are therefore critical links to understand the whole dimension of odor pollution in the environment. In this paper, odor pollution in the environment will be reviewed, including its sources and dispersion, the physical and chemical properties of odor, odor emission regulations in selected countries, odor control technologies as well as the state-of-the-art instrumentation and technology that are necessary to monitor odor, e.g., chemical sensors, olfactometry, gas chromatography, and electronic noses.

Keywords: odor, odor pollution, instrumentation, olfactometry

INTRODUCTION

Odor, which refers to unpleasant smells, is considered as an important environmental pollution issue. Attention to odor as an environmental nuisance has been growing as a result of increasing industrialization and the awareness of people's need for a clean environment. As a consequence, efforts to abate odor problems are necessary in order to maintain the quality of the environment. In this framework, understanding the odor problem and the origin and dispersion of odors, abatement and detection methods are, therefore, very important aspects of odor pollution in the environment.

One of the challenges when dealing with the odor pollution problem is the technique for the detection of odor emissions. Detection is an important aspect concerning compliance with the environmental regulations, since the detection results will be used as proof of the release of odorous substances to the environment. A successful and excellent detection technique will result in a sequence of accountably data. A reliable instrument, therefore, is necessary.

There is a growing tendency in industry to develop a detection system that enables real-time measurements. In this way, a simple and quick online-monitoring system can be established and time-consuming methods avoided. Sampling and conventional analytical procedures are then no longer necessary, since the detection and measurement of the odorous compounds can be carried out quickly and the results presented on demand.

The state-of-the-art method for detecting odor emissions is the classical olfactometry. By this method, odor assessment is based on the sensory panel of a group of selected people (panelists) with 95% probability of average odor sensitive. The method does not exclude that, physiological differences in the smelling abilities of the panel members can lead to subjective results. The olfactometry method is also very costly and requires an exact undertaking in an experienced odor laboratory in order to achieve a reliable result. Moreover, for a continuous monitoring of time-dependent processes, a system based on the human sensory system is not feasible.

A number of researches on the development of odor detection systems are currently being carried out to improve the present systems. The development of new, appropriate systems that are based on devices rather than on the human sensory system are important for increasing the acceptance by stakeholders and avoiding subjectivity in odor measurements. In this paper two points will be covered and are devoted to describe the relationship between odor pollution and the detection instrumentation:

1. Survey of the biogenic odor emissions in the environment and their abatement methods.
2. Overview of the current development in odor detection instrumentation

OVERVIEW OF ODOR POLLUTION IN THE ENVIRONMENT

Sources and Dispersion of Odors

This description is presented here to point out the relationship between any activity (industrial, agricultural, household, etc.) that can be a source of odors and their odor release. Such a relationship is important and critical in the framework of odor abatement in order to understand any activity that results in odorous gases and the kinds of odor compounds that might be produced. Table 1 shows the sources of odor in the environment and the released odor compounds. Table 2 lists some major odor compounds and their smell characteristics.

Odor substances emitted from any source will be regarded important in the context of odor pollution if they are dispersed in the surrounding area. This means that odor molecules are distributed from the odor sources into the environment. Without any dispersion process odor production will not result in complaints by the people in the surrounding area. For that reason, many researchers have studied odor dispersion in the atmosphere, using not only a model but also direct measurements. Successful examples concerning odor emissions, dispersion and dispersion modeling are cited in the following.

Kuroda et al. (1996) evaluated the emissions of malodorous compounds (volatile fatty acids, ammonia, and sulfur containing compounds), greenhouse gases (methane [CH₄], and nitrous oxide [N₂O]) from a facility for composting swine feces. They showed a basic emission pattern of malodorous compounds and two greenhouse gases during composting of solid waste. Valsaraj (1998) elaborated odor emission modeling and its relationship to meteorology, topography and dispersion; concentration of odor (µg) per cubic meter at any time within the atmosphere; and the odor emission rate at a stack and point sources. Corsi

and Olson (1998) derived models that are used for estimating volatile organic compound (VOC) emissions from wastewater. They provide a general overview of emissions estimation methods and available computer models.

Table 1. Sources of odor in the environment

Source	Odorous compounds or group	Reference
Chemical and petroleum industries:		Cheremisinoff (1992)
• Refineries	• Hydrogen sulfide, sulfur dioxide, ammonia, organic acids, hydrocarbons, mercaptans, aldehydes	
• Inorganic chemicals (fertilizers, phosphates production, soda ash, lime, sulfuric acids, etc.)	• Ammonia, aldehydes, hydrogen sulfide, sulfur dioxide	
• Organic chemicals (paint industry, plastics, rubber, soap, detergents, textiles)	• Ammonia, aldehydes, sulfur dioxide, mercaptans, organic acid	
Pharmaceutical industry	Aldehydes, aromatic, phenol, ammonia, etc.	Cheremisinoff (1992)
Rubber, plastics, glass industries	Nitro compounds (amines, oxides), sulfur oxides, solvents, aldehydes, ketones, phenol, alcohols, etc.	Cheremisinoff (1992)
Composting facilities	Ammonia, sulfur containing compounds, terpene, alcohols, aldehydes, ester, ketones, volatile fatty acids (VFA)	Gudladt (2001)
Animal feedlots	Ammonia, hydrogen sulfides, alcohol, aldehydes, N ₂ O	Janni et al. (2000)
Wastewater treatment plant	Hydrogen sulfides, mercaptan, ammonia, amines, skatoles, indoles, etc.	Huber (2002); Nurul Islam et al. (1998)

Frechen and Köster (1998) proposed a measurement method called “Odor Emission Capacity (OEC)” to describe a parameter influencing amount and variation of the odor emission mass flow, i.e. amount of odorants present in the liquid. They concluded that the determination of the OEC is a new and very valuable tool when assessing the relevance of different liquids with regard to possible odor emissions. It was also possible to determine the emission capacity of specific compounds of the liquid phase such as hydrogen sulfide or others.

McIntyre (2000) emphasized that correctly and intelligently applied atmospheric dispersion models are a valuable part of the technical toolkit for tackling odor problems. It was also pointed out that modeling is a good and useful tool for selecting and quantifying the beneficial effects of odor control programs for wastewater treatment facilities.

Wallenfang (2002) developed a gas dispersion model and verified it experimentally. The numerical model can be used to predict the dispersion pattern of odour molecules in the environment as well as to demonstrate the distribution of odour molecules through a diffused obstacles.

Table 2. Major odor compounds and their senses [Cheremisinoff, 1992]

Compound	Formula	Odor sense
Acetaldehyde	CH ₃ CHO	Pungent
Ammonia	NH ₃	Pungent
Butyric acid	CH ₃ CH ₂ CH ₂ COOH	Rancid
Diethyl sulfide	C ₂ H ₅ C ₂ H ₅ S	Garlic
Dimethyl amine	CH ₃ CH ₃ NH	Fishy
Dimethyl sulfide	CH ₃ CH ₃ S	Decayed cabbage
Ethyl mercaptan	C ₂ H ₅ SH	Decayed cabbage
Formaldehyde	HCHO	Pungent
Hydrogen sulfide	H ₂ S	Rotten eggs
Methyl mercaptan	CH ₃ SH	Decayed cabbage
Phenol	C ₆ H ₅ OH	Empyreumatic
Propyl mercaptan	C ₃ H ₇ SH	Unpleasant
Sulfur dioxide	SO ₂	Pungent
Trimethyl amine	CH ₃ CH ₃ CH ₃ N	Fishy
Valeric acid	CH ₃ CH ₂ CH ₂ CH ₂ COOH	Body odor

Characteristics of Odor Molecules

The odors that we identify in the space around us are the result of the interaction between molecules given off by the odorous material and the sensory cells located in our nose. When we sniff a rose, for example, we draw up into our nose volatile molecules that interact with the sensory cells and our interpretation of the nerve impulses generated by this interaction is positive [Gardner and Bartlett, 1999]. In the same way, however, an unpleasant odor, e.g. bad egg, is sensed because of the interaction between the odorous molecules of butyl mercaptan present in the nose cavity and the sensory cells.

Odor Dimensions

There are four odor dimensions [EPA, 2001], i.e. detectability, intensity, quality, and hedonic tone:

1. Detectability (or odor threshold) refers to the minimum concentration of odorant stimulus necessary for detection in some specified percentage of the test population. The odor threshold is determined by diluting the odor to the point where 50% of the test population or panel can no longer detect the odor.
2. Intensity is the second dimension of the sensory perception of odorants and refers to the perceived strength or magnitude of the odor sensation. Intensity increases as a function of concentration. The relationship of the perceived intensity and odor concentration is expressed by Stevens (1961) as a psychophysical power function as follows (Cha, 1998):

$$S = k I^n$$
 where

S	= perceived intensity of odor sensation (empirically determined)
I	= physical intensity (odor concentration)
k	= constant
n	= Stevens exponent
3. Odor quality is the third dimension of odor. It is expressed in descriptors, i.e. words that describe the smell of a substance. This is a qualitative attribute that is expressed in words, such as *fruity*. A list of smells is provided in Table 2 and Table 4.
4. Hedonic tone is a category judgement of the relative like (pleasantness) or dislike (unpleasantness) of the odor. It can range from “very pleasant” (high score, positive) to “unpleasant” (low score, negative).

Understanding Odor Characteristics

Understanding the odor characteristics is related to the odor pollution control technology. Physical and chemical characteristics of odor molecules should be well understood before a control technique is chosen. Card (1998) described an example of a choice between a physical and a chemical separation method for odor control. The method can be physical if the compounds are in different phases or have different particle sizes. If the compounds are dissolved in either gases or liquids, then the separation must be chemically based. The difference in the chemical characteristics of the target compounds to those of the compounds in solution determines the available methods to effect this separation.

The following are examples of the relationship between the odor characteristics and their significance for pollution control [Card, 1998]:

1. Vapor pressure. Vapor pressure is the gas phase concentration that is in equilibrium with a pure liquid phase at a particular temperature. Knowledge of the volatility of a compound greatly affects the options for odor and VOCs control. As an example, hexane is highly volatile, and adsorption is ineffective since Hexane volatilizes from

the adsorbent. In such cases, thermal oxidation may be the control technology of last resort.

2. Solubility in water. Water solubility is defined as the concentration in the aqueous phase that is in equilibrium with the pure component phase. The ability of a compound to dissolve in water is the critical factor in determining whether the compound is suitable for control by liquid scrubbing. Solubility of any odor compound or odor mixtures in water must also be taken into account, since the sampling technique in the field involves a cooling step where a part of odor compounds will be dissolved in the condensate water and be drawn from the sample.
3. Ionization. If an odor compound ionizes in solution, the performance and economics of liquid scrubbing systems can generally be enhanced. For example, the removal of ammonia and hydrogen sulfide in a gas stream is very dependent on the fact that these gases will ionize in solution. The addition of either acid (for ammonia removal) or caustics (for hydrogen sulfide removal) greatly increases the ability of liquid scrubbers to remove these compounds.

Molecular Mass, Volatility and Functional Groups

Typically, odorants have relative molecular masses between 30 and 300 g/mole. Molecules heavier than this have, in general, a vapor pressure at room temperature too low to be active odorants. The volatility of molecules is not, however, solely determined by their molecular weight. The strength of the interactions between the molecules also plays an important role, with non-polar molecules being more volatile than polar ones. A consequence of this is that most odorous molecules tend to have one or at most two polar functional groups. Molecules with more functional groups are in general too involatile to be active odorants [Gardner and Bartlett, 1999]. Table 3 lists the common simple functional groups found in a range of different types of odorous molecules, and Table 4 shows the shapes of some typical odorous molecules. These are molecules that everyone will have encountered and smelt.

Table 3. Structure of simple functional groups found in odorous molecules

Functional groups	Class of compounds	Formula	Example
Hydroxyl -OH	Alcohols	$R-O-H$	$\begin{array}{c} H & H \\ & \\ H-C & -C-O-H \\ & \\ H & H \end{array}$ <i>Ethanol</i>
Carbonyl as first or last carbon -CHO	Aldehydes	$R-\overset{O}{\parallel}C-H$	$\begin{array}{c} H & O \\ & \\ H-C & -C-H \\ \\ H \end{array}$ <i>Acetaldehyde</i>
Carbonyl as internal carbon -CO-	Ketones	$R-\overset{O}{\parallel}C-R'$	$\begin{array}{c} H & O & H \\ & & \\ H-C & -C-C-H \\ & & \\ H & & H \end{array}$ <i>Acetone</i>
Carboxyl -COOH	Carboxylic acids	$R-\overset{O}{\parallel}C-O-H$	$\begin{array}{c} H & O \\ & \\ H-C & -C-O-H \\ \\ H \end{array}$ <i>Acetic acid</i>
Amino -NH ₂	Amines	$R-\overset{H}{ }N-H$	$\begin{array}{c} H \\ \\ H-C-N-H \\ & \\ H & H \end{array}$ <i>Methyl amine</i>
Sulfhydryl -SH	Thiols	$R-S-H$	$\begin{array}{c} H & H & H & H \\ & & & \\ O-C & -C-C-S \\ & & \\ H & & H \end{array}$ <i>Mercaptoethanol</i>

Observations on two composting facilities in Bonn and Stuttgart, Germany, during field measurements showed that the results are also in accordance. The odor compounds released from a composting facility located near Stuttgart consisted of compounds whose molecular weights are in between 17 g/mole (ammonia) and 152 g/mole (thujone). Another composting facility near Bonn also showed that the molecular masses of odorous compounds are in between 46 g/mole (ethanol) and 136 g/mole (limonene) (Yuwono et al., 2003).

Table 4. The shapes of some typical odorous molecules (extracted from Smells Database, Department of Chemistry U.C. Berkeley, CA, USA)



Odor molecule	Space-fill representation	Wire-frame representation
<p>Ethyl butyrate (fruity) Chemical name: Butanoic acid ethyl ester Common name: Ethyl butyrate Formula: $C_6H_{12}O_2$</p>		
<p>Benzaldehyde (bitter almond) Chemical name: Benzaldehyde Common name: benzaldehyde Formula: C_7H_6O</p>		
<p>Citral (lemon) Chemical name: 3,7-Dimethyl-2, 6-octadienal Common name: Geranial, Citral A Formula: $C_{10}H_{16}O$</p>		
<p>Acetic acid (acid) Chemical name: Acetic acid Formula: $C_2H_4O_2$</p>		
<p>Rotten Eggs Chemical name: Hydrogen sulfide Common name: Hydrogen sulfide Formula: H_2S</p>		

Table 4. (continued)

Odor molecule	Space-fill Representation	Wire-frame Representation
Smells like almond (extremely toxic) Chemical name: Hydrogen cyanide Common name: Hydrogen cyanide Formula: HCN		
Rancid cheese, sweaty, putrid Chemical name: 3-Methylbutanoic acid Common name: Isovaleric acid Formula: C ₅ H ₁₀ O ₂		
Rotten fish, ammonia like Chemical name: N, N-Dimethylmethanamine Common name: Trimethyl amine Formula: C ₃ H ₉ N		
Fecal odor Chemical name: 3-Methyl-1H-indole Common name: Skatole Formula: C ₉ H ₉ N		
Pungent odor Chemical name: 2-Methylpropanal Common name: Isobutyraldehyde Formula: C ₄ H ₈ O		

Odor as an Environmental Nuisance

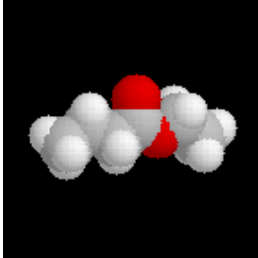
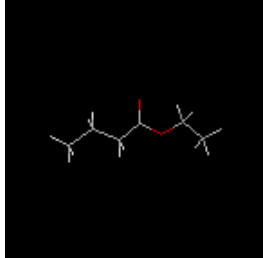
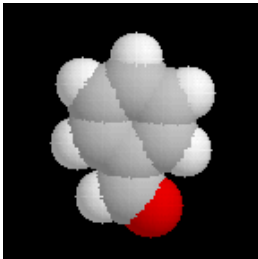
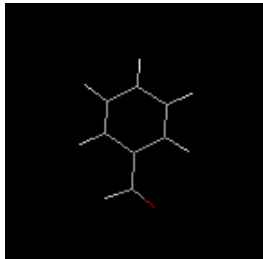
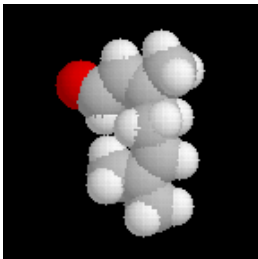
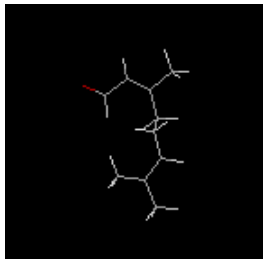
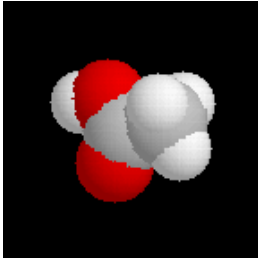
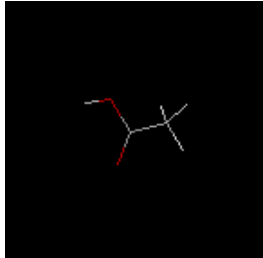
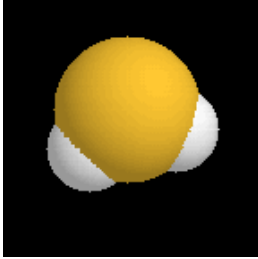
A list of unpleasant odor compounds that are seen as environmental nuisances is presented in Table 2. However, agreement on whether an odor is pleasant or unpleasant is sometimes thought of as being very personal. Pleasantness or unpleasantness is a result of emotions in the individuals. The following indicates ideas of pleasantness and unpleasantness and the human response to odors [Cheremisinoff, 1992]:

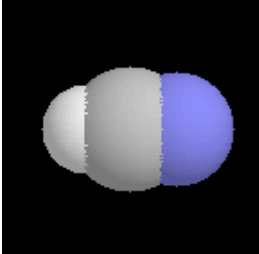
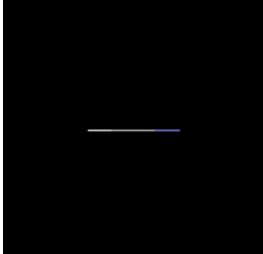
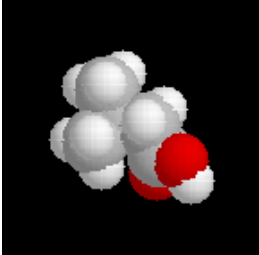
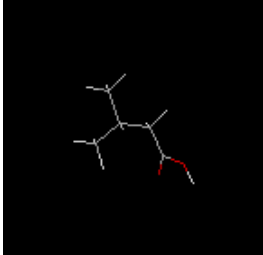
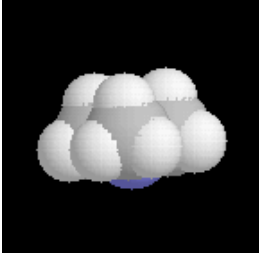
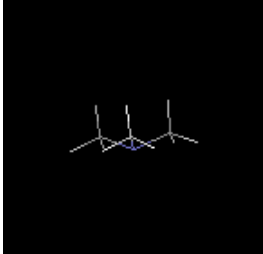
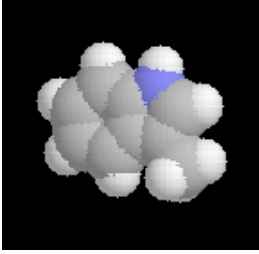
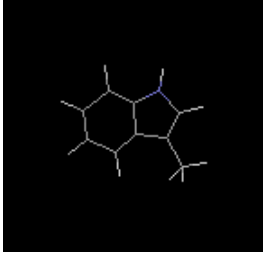
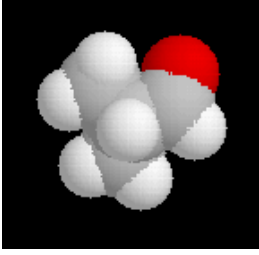
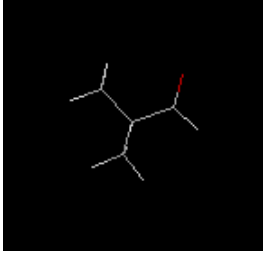
- Human reactions to odors are similar to our reactions to other sense stimuli: involuntary and spontaneous, either liking or disliking, or indifference.
- Reasons for the above cannot be interpreted; i.e. usually the reasons, if there are any, show no trends or give no explanations.
- Previous experience with an odor or with similar odors sometimes determines if an odor is liked or disliked.
- According to bodily needs, food smells are pleasant or unpleasant.
- Pleasant odors tend to feed those emotions that are affected by “beautiful” things in the environment.

There is a general agreement on which odors are experienced as unpleasant, e.g., odors that are pungent (ammonia), rotten eggs, stinking (garbage wastes), and rancid odors. Odors that are sweet (flowers), fresh (outdoor odors), and appetizing (food), are mostly experienced as pleasant odors. A provisional conclusion can be drawn stating that if an odor is regarded as an environmental nuisance, it means that the odor is an unpleasant one.

Individual sensitivity to the quality and intensity of an odorant can vary significantly, and this variability accounts for the difference in sensory and physical responses experienced by individuals who inhale the same amounts and types of compounds. This distinction between “odor”, which is a sensation, and “odorant”, which is a volatile chemical compound, is important for everyone dealing with the odor issue to recognize. When odorants are emitted into the air, individuals may or may not perceive an odor. When people perceive what they regard as unacceptable amounts or types of odor, odorous emissions can become an “odor problem” [EPA, 2000]. Simply, an odor problem results from an odor that is unpleasant.

Numerous regulations on control of odor in the environment are being passed in many countries, especially in industrialized countries, where the attention to and demand for clean air is an important aspect of the human environment. This results in odor emission regulations and air quality norms.

In Germany, for example, regulations concerning odor control are very strict due to a high population density and large number of waste treatment plants. Thus, it is almost impossible to find locations for treatment plants without annoying people with odor emissions. Many plants have already been built near residential areas and people complain about odor emissions [Bockreis, 1999]. A number of statutes, regulations and guidelines concerning odor that in effect regulate air emissions from facilities in Germany, Canada and USA are listed in Table 5.

Table 5. Odor-related regulations in selected countries (USA, Germany, and Canada)
(adapted from Hellwig (1998) and Bockreis (1999))

Country	Regulations	Remarks
USA	• Clean Air Act (CAA)	Regulates stationary sources of volatile organic compounds (VOC)
	• Resource Conservation and Recovery Act (RCRA)	Regulates emissions arising from transportation and storage of hazardous waste and disposal
	• Toxic Substances Control Act (TSCA)	Limits the distribution, use or disposal of chemicals that can have adverse health and environmental effects
	• Comprehensive Environmental Response, Compensation, and Liability Act of 1980 (CERCLA)	Requires states to establish a process for developing local emergency preparedness programs and to receive and disseminate information on hazardous chemicals present at facilities within local communities
	• Occupational Safety and Health Act (OSHA)	Provides the basis for regulations protecting workers in the workplace
Germany	• VDI 3881	Olfactometry
	• GIRL (<i>Geruchsimmissions-Richtlinie</i>)	Odor pollutants guidelines
	• VDI 3940 [VDI 1991]	Determination of odor in ambient air by field inspections
Canada	• The Environmental Protection and Enhancement Act (EAPA) in Alberta Province	Prohibitions against the release of compounds that cause a “significant adverse effect”
	• Waste Management act in British Columbia Province	Defines an <i>air contaminant</i> as a substance that “interferes or is capable of interfering with the normal conduct of business”
	• The Environment Act in Manitoba Province	Includes odor in its definition of <i>pollutant</i> , where it may “interfere with or is likely to interfere with the comfort, well-being, livelihood or enjoyment of life by a person”

Odor Pollution Reduction Technologies

There are several methods to reduce odor coming from waste gases. However, there is no single treatment technology that can effectively and economically be applied to every industrial or commercial application. The effectiveness of a technology can often be defined by the flow rates and concentrations at which adequate cost-effective treatment can be expected. For all technologies, cost-effectiveness is site specific [Devanny et al., 1999]. Seasonal fluctuations can also be an important parameter for a typical odor controlling method, as reported by Gao et al. (2001) who made a technical and economic comparison between biofiltration and wet chemical oxidation (scrubbing) for odor control at wastewater treatment plants. The following parts are overview of the methods currently available.

Biological Systems

Biological treatment is effective and economical for low concentrations of contaminants in large quantities of air [Deviny et al., 1999; Wübker and Friedrich, 1996]. On the other hand, chemical treatment requires aggressive additives, causing problems to the environment, whereas physical processes do not eliminate but transfer the pollutants to a new stream to be treated [Wübker and Friedrich, 1996].

Biological systems for odor control rely basically on the microorganism activity that converts odor compounds in the waste air or wastewater to carbon dioxide and water as in a chemical system. Biological systems include biofilters, biological scrubbers (or bioscrubbers), and biological trickling filters (or biotrickling filters). They are often known as bioreactors. Successful biodegradation of odor using biofilters, biotrickling filters and bioscrubbers are listed in Table 6. The differences between these bioreactors and the advantages as well as disadvantages are presented in Tables 7 and 8 and Figure 1.

Table 6. Examples of successful odor biodegradation using biofilter, biotrickling filter and bioscrubber

Abatement method	Biodegraded odor compounds	Process efficiency	Reference
Biofilter	• BTEX (benzene, toluene, ethylbenzene, o-xylene)	≥ 90%	Abumaizar et al. (1998)
	• Hydrogen sulfide (H ₂ S), ammonia (NH ₃)	≥ 95%	Chung et al. (2000)
	• Trichloroethylene (C ₂ HCl ₃)	30 - 60%	Cox et al. (1998)
	• Ammonia (NH ₃)	≥ 95%	Liang et al. (2000)
	• Acrylonitrile (C ₃ H ₃ N)	≥ 95%	Lu et al. (2000)
	• Toluene (C ₇ H ₈)	84%	Parvatiyar et al. (1996)
			57 - 99%
Biotrickling filter	• Toluene (C ₇ H ₈)	94%	Peixoto and Mota (1998)
	• Styrene (C ₈ H ₈)	97 - 99%	Sorial et al. (1998)
	• Diethyl ether (C ₄ H ₁₀ O)	72 - 99%	Zhu et al. (1996)
		95%	Zhu et al. (1998)
Bioscrubber	• Hydrogen sulfide (H ₂ S)	99%	Hansen and Rindel (2000); Koe and Yang (2000)
	• n-Butanol (C ₄ H ₁₀ O)	84 - 100%	Wuebker and Friedrich (1996)
Hybrid bioreactor:			
	• Biofilter and bubble column	• Benzene (C ₆ H ₆)	65 - 100%
Biofilter and bioscrubber	• Ammonia (NH ₃)	83%	Weckhuysen et al. (1994)
	• Butanal (C ₄ H ₈ O)	80%	

Table 7. Difference between biofilter, biotrickling filter and bioscrubber in terms of microorganisms and water phase [Devinny et al., 1999]

Reactor	Microorganisms	Water phase
Biofilter	Fixed	Stationary
Biotrickling filter	Fixed	Flowing
Bioscrubber	Suspended	Flowing

Table 8. Relative advantages and disadvantages of air phase bioreactors [Wittorf et al., 1993 *in* Edwards and Nirmalakhandan, 1996]

Biofilter	Biotrickling filters	Bioscrubbers
Advantages		
<ul style="list-style-type: none"> • Simple operation • Low investment costs • Low running costs • Degradation of less water-soluble pollutant • Suitable for reduction of odorous pollutants 	<ul style="list-style-type: none"> • Simple operation • Low investments costs • Low running costs • Suitable for moderately contaminated waste air • Ability to control pH • Ability to add nutrients 	<ul style="list-style-type: none"> • Good process control possible • High mass transfer • Suitable for highly contaminated waste air • Suitable for process modeling • High operational stability • Ability to add nutrients
Disadvantages		
<ul style="list-style-type: none"> • Low waste-air volumetric flow rate • Only low pollutant concentration • Process control impossible • Channeling of air flow is normal • Limited service life of filter bed • Excess biomass not disposable 	<ul style="list-style-type: none"> • Limited process control • Channeling can be a problem • Limit service life of filter bed • Excess biomass not disposable 	<ul style="list-style-type: none"> • High investment cost • High running cost • Production of excess biomass • Disposal of water • Possible plugging in adsorption stage

Biofilters are the most widely used and accepted vapor-phase biological treatment systems, and have been systematically applied in various forms throughout many parts of the world for more than 30 years [Skladany et al., 1999; McNevin and Barford, 2000].

In biological scrubbers and biological trickling filters, gas contaminants are absorbed in a free liquid phase prior to biodegradation by either suspended or immobilized microbes. In a biotrickling filter, microbes fixed to an inorganic packing material and suspended microbes in the water phase degrade the absorbed contaminants as they pass through the reactor. In bioscrubbers, after initial contaminant absorption, the degradation of the contaminants is performed by a suspended consortium of microbes in a separate vessel [Devinny et al., 1999].

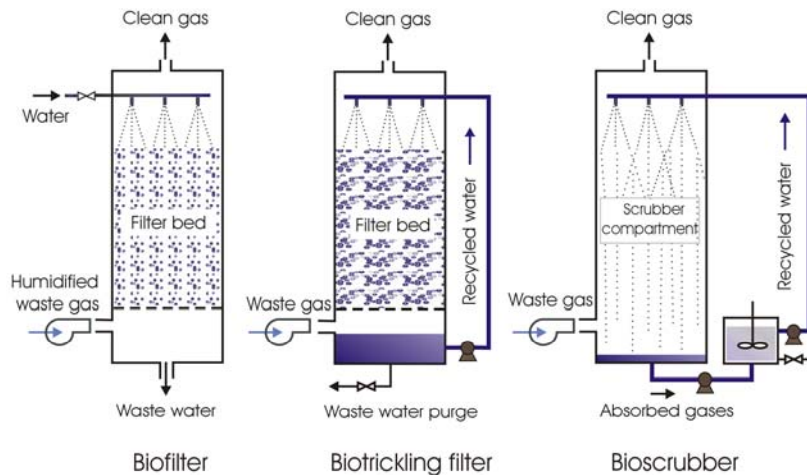

Figure 1. Biofilter, biotrickling filter and bioscrubber

Chemical Systems and Hybrid Systems

As regards chemical systems, several technologies are currently available. Some of them function through the addition of chemicals to liquid, thermal oxidation, and chemical scrubbing.

Addition of chemicals to liquids to control odor relies on the reaction of the odorous components with a chemical treatment reagent. The chemical treatment reagent alters the concentration of the odorous components in the aqueous phase and hence lowers the emission of the component. For example, a common odorous component in wastewater is hydrogen sulfide (H_2S). Chemical addition can alter the oxygen balance in the wastewater by (1) oxidizing sulfides, (2) precipitating dissolved sulfides, or (3) changing the ability of the sulfate- or organic sulfides-reducing organisms to generate sulfides [Bonani, 1998]. Some examples of oxidants used are chlorine (Cl_2), sodium hypochlorite (NaOCl), or potassium permanganate (KMnO_4), and hydrogen peroxide (H_2O_2).

In thermal oxidation, a hydrocarbon odor compound is converted to carbon dioxide and water vapor in the presence of oxygen and heat at a temperature of 700 to 1400°C. With catalysts such as platinum, palladium, and rubidium, this process can be achieved at a temperature of 300 to 700°C. A general equation showing this relationship is:

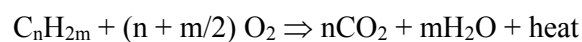

When applying chemical scrubbing, odor compounds are fed in a reaction chamber in which contact between odor compounds and a fog or droplet of chemical occurs. This odor control system removes odor by spraying very fine mist droplets of a controlled diluted chemical solution into an odorous stream that passes through a hollow, cylindrical reaction chamber. Cleaned air leaving the reaction chamber is discharged through the exhaust stack to the atmosphere (Figure 2).

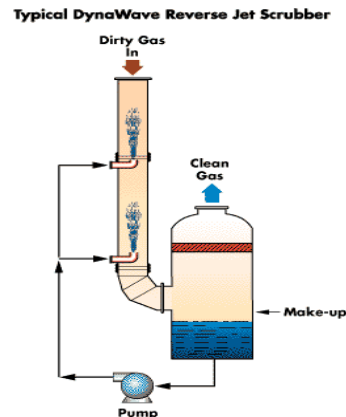

Figure 2. A typical scrubber (Enviro-Chem System, Monsanto Co.)

A hybrid system is a combination of different systems. In many industrial applications, this is considered to be more cost-effective than a single standard control. Although hybrid systems can offer improved-cost effectiveness, they require a higher degree of preliminary engineering and understanding of each component of the hybrid system. Therefore, it is important to carefully select the cases in which hybrid control systems are employed [Patkar, 1998]. Yeom and Yoo (1999) showed a novel hybrid system to remove benzene by using a combination of biofilter and bubble column. It was shown that 65-100% removal efficiency was reached, depending on the airflow rate and benzene concentration.

ODOR POLLUTION DETECTION INSTRUMENTATION

Chemical Sensors

In the field of sensor technology, the term “chemical sensor” addresses a special group of sensors that are different to other sensors, i.e. thermal sensors, magnetic sensors, optical sensors, and mechanical sensors (Figure 3). According to the definition, a chemical sensor is a device that responds to a particular analyte in a selective way through a chemical reaction, and which can be used for the qualitative or quantitative determination of the analyte. It can be seen that such a definition encompasses all sensors based on chemical reactions including biosensors, which make use of highly specific and sensitive biochemicals, and biological reactions for species recognition [Cattrall, 1997].

Göpel and Schierbaum (1991) proposed another definition. Chemical or biochemical sensors are (miniaturized) devices that convert a chemical state into an electronic signal. A chemical state is determined by the different concentrations, partial pressures, or activities of particles such as atoms, molecules, ions, or biologically relevant compounds to be detected in the gas, liquid, or solid phase. The chemical state of the environment with its different compounds determines the complete analytical information.

Cattrall (1997) classified the chemical sensors according to the transducer type into the following groups: electrochemical, optical, heat-sensitive, and mass-sensitive. Electrochemical sensors include potentiometric sensors and voltametric/ampereometric sensors. Optical sensors, which are often referred to as ‘optodes’, rely on the association between spectroscopic measurements and the chemical reaction. Heat sensitive sensors are often known as calorimetric sensors in which the heat of a chemical reaction involving the analyte is monitored with a transducer such as a thermistor or a platinum thermometer. Flammable gas sensors make use of this principle.

Mass sensitive sensors make use of the piezoelectric effect and include devices such as the surface acoustic wave (SAW) sensor and are particularly useful as gas sensors. They rely on a change in mass on the surface of an oscillating crystal, which shifts the frequency of oscillation. The extent of the frequency shift is a measure of the amount of material adsorbed on the surface [Cattrall, 1997]. The bulk acoustic wave sensor (BAW) also belongs to the group of mass sensitive sensors. BAW is also referred to as the quartz crystal microbalance (QCM) or thickness shear mode device (TSM). A more detailed explanation of the QCM is presented in the next sub-chapters.

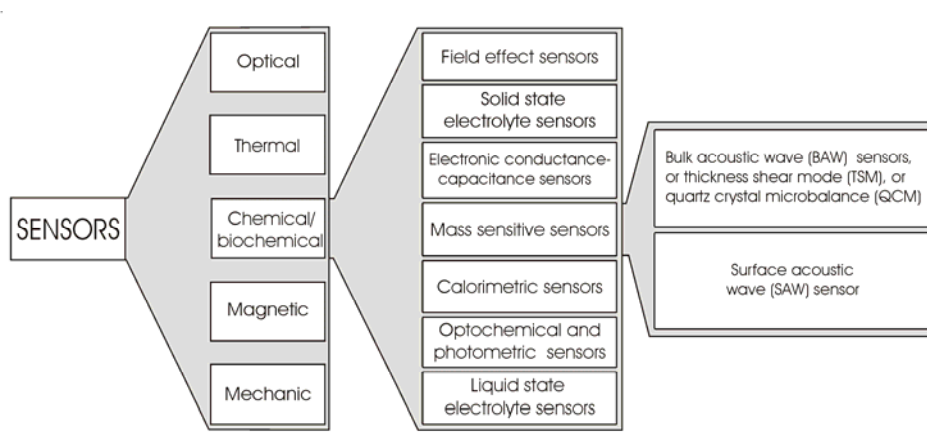

Figure 3. Classification of sensors showing the sensor types, including chemical sensors, mass sensitive sensors and the quartz crystal microbalance (QCM) sensor

Göpel and Schierbaum (1991) classified chemical and biochemical sensors according to the different sensor characteristics used for particle detection. The most commonly used properties are potential (field effect sensors), voltages (solid-state electrolyte sensors), conductivity and capacity (electronic conductance and capacitance sensors), mass (mass sensitive sensors), heat (calorimetric sensors), or optical constant (optochemical and photometric sensors) and voltages (liquid state electrolyte sensors) (see Figure 3).

The working principles of a chemical sensor are primarily based on the interaction between sample input (e.g. odor molecules) and the chemically sensitive materials on the sensor surface. This interaction results in a change of mass and it is then converted into an

electronic signal by a transducer. Figure 4 shows the basic components of a chemical sensor.

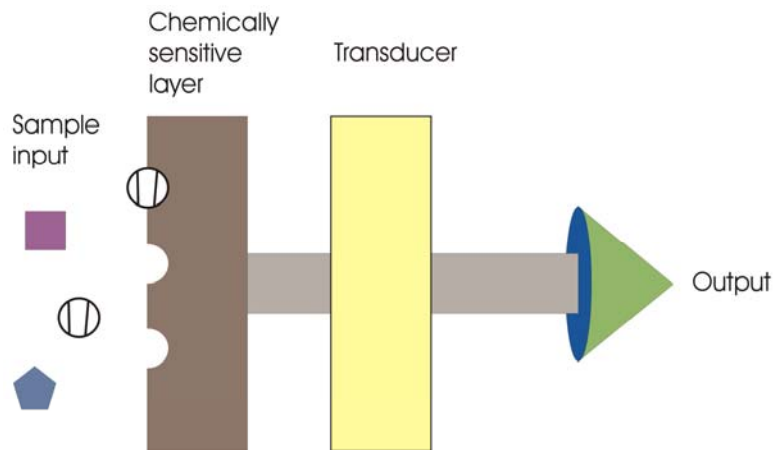

Figure 4. Basic components of a chemical sensor (adapted from Gardner and Bartlett, 1999)

The application fields of chemical sensors are very broad. Among these are [Göpel and Schierbaum, 1991]:

1. Environmental control (air, water, soil)
2. Working area measurements (workplace, household, car, etc.)
3. Emission measurements (car, waste water, etc.)
4. Process control and regulation (biotechnological and chemical plants, fermentation process, etc.)
5. Medical applications (clinical diagnostics, anesthetics, veterinary)
6. Agricultural (analysis in agriculture and gardening, detection of pesticides, etc.).

In the context detection of odor and volatile organic compound (VOC) emissions, a brief list of widespread applications of chemical sensors developed during the past years is summarized in Table 9.

Table 9. Chemical sensor applications relevant to the odor and volatile organic compound (VOC) emissions detection

Application fields	Detection objects	Sensors	Reference
1. Environmental control	- Propane, Propanol	- Metal oxides sensor with multivariate analysis	- Althainz et al. (1996)
	- Solvent vapors (Pentane, Hexane, Heptane, etc)	- QCM with PCA and neural network	- Auge et al. (1995)
2. Measurements in working areas	- Gas mixture analysis	- MOSFET sensor with PCA and artificial neural network	- Eklöv and Lundström (1999)
	- Harmful organic vapors detection	- QCM sensors	- Dickert et al. (2000)
3. Emission measurements	- Waste water separation	- Polypyrrole sensors with multivariate analysis	- Bourgeois and Stuetz (2000)
	- Ammonia emission	- QCM sensor array	- Boeker et al. (2000)
4. Process control and regulation	- Bioreactor off-gas composition monitoring	- MOSFET sensor with PCA	- Bachinger et al. (2000)
	- Block milk products classification	- Neotronics eNOSE electronic nose	- Zondervan et al. (1999)
5. Medical applications	- Urine analysis	- QCM sensors with PCA	- Di Natale et al. (1999)
	- Human skin odor analysis	- QCM sensors with self-organizing map (SOM) analysis	- Di Natale et al. (2000)
	- Human breath analysis	- Metal oxide sensors with signal pattern evaluation	- Ehrmann et al. (2000)
6. Agricultural	- Vinegar discrimination	- AromaScan electronic nose	- Anklam et al. (1998)
	- Boar taint intensity discrimination	- Conducting polymer sensor array with pattern recognition routines	- Annor-Frempong et al. (1998)

Olfactometry and Gas Chromatography

Olfactometer is the state-of-the-art odor measurement system. It is used to measure the odor detection threshold (or recognition threshold) and the hedonic tone of an odor

A. Yuwono and P. Schulze Lammers . “Odor Pollution in the Environment and the Detection Instrumentation”. *Agricultural Engineering International: the CIGR Journal of Scientific Research and Development*. Invited Overview Paper. Vol. VI. July, 2004.

substance. The odor detection threshold is the lowest concentration of any odor substance that can be detected by 50% of the test population (known as panelists or assessors), whereas the hedonic tone is a scale based on ratings which measure the degree of pleasure provided by a specific characteristic of an odor substance.

An odor measurement is expressed as an odor unit (OU). In European countries (EU), the unit used is the European Odor Unit (OU_E), a unit that has caused much confusion in the research community because its format differs from those commonly used to describe concentrations, i.e. mass per volume (kg/m^3) or volume per volume (ppm) [Zhang, 2001]. In 2000, Australia and New Zealand jointly set up a new odor-testing standard essentially identical to the European Standard. By definition, 1 OU_E is the amount of odorants that, when evaporated into 1 m^3 of a neutral gas in standard conditions, elicits a physiological response from a human panel equivalent to that elicited by 123 μg of n-butanol evaporated in 1 m^3 gas in standard conditions [Zhang, 2001]. According to the EPA definition [EPA, 2001], 123 μg of n-butanol is known as one European Reference Odor Mass (EROM).

The hedonic tone is a subjective judgement of the relative pleasantness or unpleasantness of any odor. A numbering system can be applied to this scale, ranging from a small number for “dislike” (or “unpleasant”) and a large number for “like” (or “pleasant”). Another quantification system for hedonic tone is the use of a 20-point scale, starting from “-10” for unpleasant and “+10” for pleasant odors. An example of a hedonic tone for any odor substance under assessment can also be defined as follows:

1=dislike very much; 2=dislike; 3=neither like nor dislike; 4=like; 5=like very much.

The problem involved in the use of olfactometry is the subjectivity of the panel’s members. An exact replication of a measurement of the same substance is not possible, since the sensitivity of different panels is obviously not the same. Furthermore, for measuring harmful gases, a panel certainly cannot be recommended. Olfactory fatigue is also a common side-effect observed in panel members.

Odor compounds can also be recognized by means of analytical instruments such as gas chromatography. An odor-containing gas sample is fed onto the instrument through the head of the chromatographic column. The sample is then transported through the column by the flow of the inert and gaseous mobile phase of the carrier gas. Later, the detector responds to the compounds but not to the carrier gas. The signal from the detector is expressed as a graph known as a chromatograph. By comparing the respective peaks and the reference graph, the compound present in the sample can be distinguished. Although the measuring system is simple, the costs are high, since the instrumentation is expensive. Gardner and Bartlett (1999) added that the use of gas chromatography requires considerable skills. For the above reasons, the technique is not used for routine evaluation.

Electronic Noses

An electronic nose (E-nose) is an instrument that is designed to approach or to substitute the function of the biological olfaction system (e.g. human nose). Gardner and Bartlett (1999) defined the E-nose as an instrument that comprises an array of electronic, chemical sensors

with partial specificity and an appropriate pattern recognition system, capable of recognizing simple or complex odors. This definition restricts the term E-nose to those types of sensor array systems that are specifically used to sense odorous molecules in an analogous manner to the human nose. According to another definition by Pearce et al. (2002), the E-nose is a machine that is designed to detect and discriminate among complex odors using a sensor array. The sensor array consists of broadly tuned (non-specific) sensors that are treated with a variety of odor-sensitive biological or chemical materials. An odor stimulus generates a characteristic fingerprint (or smell-print) from the sensor array. Patterns or fingerprints from known odors are used to construct a database and train a pattern recognition system so that unknown odors can subsequently be classified and identified. Thus, the E-nose instrument is comprised of hardware components for collecting and transporting odors to the sensor array as well as an electronic circuitry to digitize and store the sensor responses for signal processing. A diagram of the basic components of a typical E-nose is depicted in Figure 5.

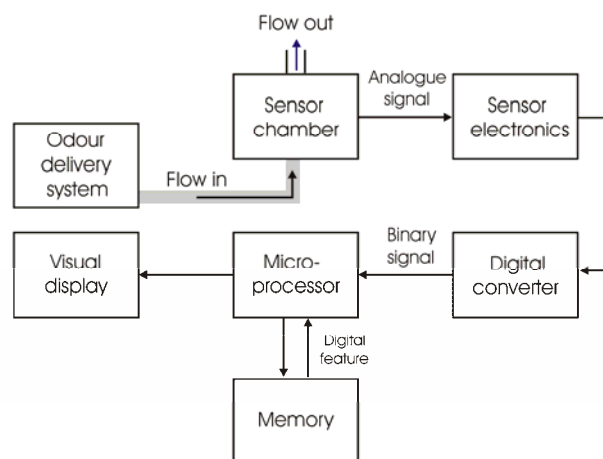

Figure 5. Basic components of an electronic nose (E-nose) instrument system (adapted from Gardner and Bartlett, 1999)

Considerable research has been directed towards the development of E-nose instrumentation over the past decade. Numerous research groups now exist in countries such as Australia, Denmark, France, Germany, Japan, Sweden, UK and USA [Gardner and Bartlett, 1996]. There is also increasing interest in the research, development and application of E-noses, i.e. of sensors and sensor arrays, with the aim to [Göpel, 1998]:

- Complement techniques of analytical chemistry in order to classify gas mixtures, odors, air quality, or toxicity.
- Develop cheap and small online instruments for fast imaging of specific chemicals, odors, or toxic substances with high spatial and time resolution (including, e.g., instruments required for quality and process control).
- Develop new materials for odor detection based on molecular recognition principles that are similar to those in the human nose.

Among these, the last point (development of new materials) might be the most difficult problem. This is in line with the fact that the fundamental problem in the application of QCM sensors is to find a suitable coating layer and a method of reproducibility when applying it [O’Sullivan and Guilbault, 1999].

There are a number of records of E-nose applications in daily life, including medicine, agricultural fields, environmental monitoring, etc. In the following, a selection of applications regarding odor detection, monitoring or measurement are listed: identification of odors from reagents (ethanol, ether, acetone, ethyl acetate), liquors (beer, spirit, samshu, wine), and perfumes (phenethyl alcohol, ionone, vanillyl alcohol, ethyl isobutyrate, thymol) [Yang et al., 2000]; measurements of sewage odors [Stuetz et al., 1998; Stuetz et al., 1999]; characterization of olives oil based on their volatile substances [Stella et al., 2000]; diabetes diagnosis based on the expired breath of diabetics [Ping et al., 1997]; discrimination of polymer samples used in the automotive industry [Morvan et al., 2000]. A number of electronic nose systems currently available on the market [Strike et al., 1999] are *Alpha MOS*, *AromaScan*, *Bloodhound*, *Lennartz Electronic*, *Smart Nose*, *Cyrano Sciences*, etc. These utilize a range of sensor technologies either alone or in combination.

Metal Oxide Sensors (MOS)

Metal oxides sensors are devices that translate the changes in the concentration of gaseous chemical species into electrical signals. They consist basically of a sensitive layer, an insulating layer, two electrodes and a heating heater (Barsan, 2002). A scheme of a MOS is given in Figure 6. The semiconducting layer oxidizes the sample compound at a temperature level of 250 to 450 °C. When the semiconducting substance absorbs the released electrons, its conductivity changes. In consequence, the change of resistance in the electrical circuit is registered. The sensitivity of the sensor can be adjusted by choosing different operation temperatures and by dotation with noble metals as catalytic dopants. The application of pattern recognition systems is made difficult by the fact that the dependency of the sensor signal on the concentration of the gaseous species is generally not linear.

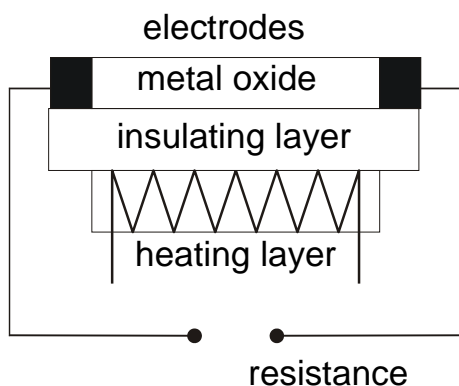

Figure 6. Scheme of a metal oxide sensor

Table 10. Applications of metal oxide sensors for odor detection

Detected odor(s)	Reference
<ul style="list-style-type: none"> ▪ Five malodors collected in the field: printing houses, paint shop, waste water treatment plant, urban waste composting facilities, rendering plant 	Romain et al., 2000
<ul style="list-style-type: none"> ▪ Selective detection of CO and NH₃ 	Chambon et al, 1999
<ul style="list-style-type: none"> ▪ Organic vapors: benzene, toluene, and methanol 	Wang et al., 1995
<ul style="list-style-type: none"> ▪ Trimethylamine 	Kwon et al., 1998

Conducting Polymer Sensors

Conducting polymer sensors (see Figure 7) are being widely used for odor sensing in the form of arrays consisting of highly sensitive, scarcely selective, chemoresistive sensors characterized by different sensitivity spectra (Stussi, 1997). The working principle of the sensor is based on the change of the conductivity during the diffusion of gaseous molecules in the polymer layer. Due to the use of pyrrol as a master polymonomer, the sensor is highly sensitive to polar compounds. By an inclusion of different metal ions into the polymer, the sensor can be adjusted for various chemical species.

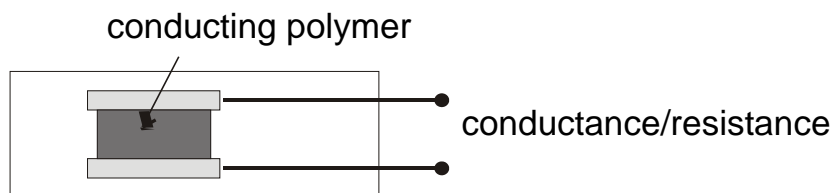

Figure 7. Scheme of a conducting polymer sensor

An application in the classification of odors from different Spanish wines is explained in Guadarrama et al.(2000). Another example of an application is the sensing of aqueous ammonia (Koul et al., 2001).

Quartz Crystal Microbalance (QCM) Sensor

The quartz crystal microbalance (QCM) sensor is an example of an extremely sensitive detector of mass changes [Cattrall, 1997; Nanto et al., 2000]. Quartz crystal is an earth mineral that is used as the basic material of the sensor, and the term “microbalance” is used to describe the highly sensitive ability of this sensor to detect a very small (“micro”) mass change on the sensor surface.

A QCM sensor makes use of the piezoelectric effect of quartz crystal materials. Piezoelectricity literally means “pressure electricity” (“piezo” is Greek for pressure), i.e. a

phenomenon where a mechanical stress (e.g. compression) taking place on the quartz crystal produces an electric potential, and conversely, an application of electric potential results in mechanical deformations (strain) on the quartz. Jacques and Pierre Curie first discovered such a phenomenon in 1880.

By employing these properties, wave phenomena can be generated. The velocity of the waves and, as a result, their frequencies are influenced by a large number of parameters, including mass effects at the surface of the piezoelectric material [Nieuwenhuizen and Venema, 1991].

A QCM sensor is a kind of mass sensitive sensor, a member of the chemical sensors group. The basic material of the QCM sensor consists of quartz crystal, which is equipped with metal electrodes (e.g. gold). A sensitive coating material on the sensor surface is used to enable detection of the measurand (analyte) in the environment. An appropriate electronic circuit is necessary to make conversion of the measured quantity to an electrical signal possible.

The basic working principles of the quartz crystal microbalance sensor are depicted in Figure 8. Analytes that are present in the surrounding space (e.g. a measuring chamber) of a QCM sensor will interact with the sensitive coating material on the sensor surface. In this interaction, analyte molecules are adsorbed into or absorbed onto the sensitive coating material (e.g. polymer). The adsorption or absorption of the analytes by the coating material results in a mass change on the sensor surface. Consequently, the mass change on the sensor surface is converted to the frequency change.

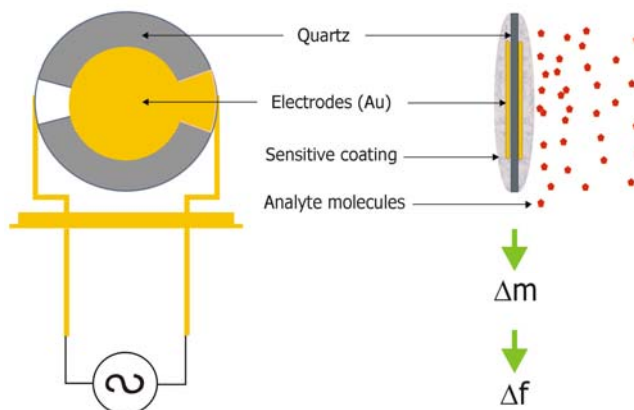

Figure 8. Basic working principles of a quartz crystal microbalance (QCM) sensor

Using an equation derived by Sauerbrey [Sauerbrey, 1959], a mass change on a QCM sensor surface due to adsorption of any analyte by sensitive coating material can be expressed in a frequency change quantity as follows:

$$\Delta f = -2.3 \times 10^6 F^2 (\Delta m/A)$$

where:

Δf = the frequency change [Hz]

F = the oscillating frequency of the quartz crystal [MHz] (for a typical AT-Quartz, $F = 10$ MHz)

Δm = the mass change of the adsorbed analyte, i.e. odor substance [g]

A = the area coated by the film [cm²].

The interaction between odor molecules and the sensitive coating materials (known as “guest-host interaction”) plays an important role in the detection process. In this interaction, the analyte (i.e. the odor molecules) acts as the guest, whereas the sensitive coating material is the host. There are a number of chemically sensitive material classes, e.g. [Göpel, 1998]:

- a. Polymers (polyethers, polyurethanes, polysiloxanes, polypyroles, nafion, etc.)
- b. Molecular crystals (phthalocyanines, porphyrines, etc.)
- c. Supramolecular structures (calixarenes, zeolites, cyclodextrines, cyclophanes, etc.)

Because of its importance, special attention has been paid to this guest-host interaction by researchers during the last decades. Studies concerning its energy aspects, for example, have been carried out by Dickert et al. (2000^a). They show that the sensor signal of these supramolecular analyte-receptors can be predicted by a method that uses estimated free energies of the guest-host complex formation. Another study [Dickert et al., 2000^b] demonstrated the application of molecular modeling to provide meaningful structural information on the guest-host interactions of cyclodextrine and chloroform. In this way, computational chemistry helps to achieve a better understanding of what happens during the inclusion process. This saves time- and money-consuming synthesis and makes molecular modeling an excellent tool for the design of sophisticated chemical sensitive layers.

More detailed studies on coating materials have been performed by Buhlmann et al. (1995) on clathrates as coating materials for dielectric transducers with regard to organic solvent vapor sensors; by van de Leur and van der Waal (1999) on polypyrrolle for gas and vapor detection; by Cao et al. (1996) on plasticised PVC coatings; Weiß et al. (1995) on self-assembled monolayers of supramolecular compounds for chemical sensors; and by Zhou et al. (1995) on silicon-containing monomers, oligomers and polymers as sensitive coatings for the detection of organic solvent vapors.

The method for determining mass by measuring the change in the oscillation frequency of a quartz crystal is extremely sensitive [Cattrall, 1997; Ali et al., 1999; Abe and Esashi, 2000; Nanto et al., 2000], since this type of crystal has a sensitivity of about 10⁻⁹ g/Hz with a detection limit of around 10⁻¹² g [Cattrall, 1997].

Besides economical parameters (e.g. price), there are a number of technical criteria determining the performance of a QCM sensor or sensor array, including (1) sensitivity (2) detection limit (3) selectivity (4) stability (5) response time and recovery time, and (6) sensor drift. In the perspective of the use of a QCM sensor for gas detection, a QCM sensor is sensitive if a small change of gas concentration can be detected by the sensor and expressed in a relatively large frequency change number. The second criterion (detection limit) is important to describe the ability of a sensor to detect a very low concentration of an analyte. The lower the detection limit of a sensor is the better. It is useful especially for

detection of trace gases. The third criterion (selectivity) is used to indicate that the sensor, together with the sensitive coating material, detects only a certain target analyte or a group of analytes, according to the designed objective.

The fourth criterion (stability) is necessary to ensure that the sensor is long-term stable (endure) enough to be implemented in a variety of measurement locations and situations and to show stable results. The criteria 'response time' is the time required for a sensor to read a certain percentage (e.g. 80%) of a full-scale reading after being exposed to a full-scale concentration of a given gas, whereas 'recovery time' indicates the time required by a sensor to return to normal condition and to be ready for a new measurement after a measurement cycle. The criterion 'sensor drift' is a phenomenon where an undesired change in output takes place over a period of time that is unrelated to input. Sensor drift can be due to aging, temperature effects, or sensor "poisoning", etc.

The QCM sensor can be used as a single sensor or as a group of sensors, known as sensor array. A sensor array, however, is not simply a group of a number of discrete sensors that are used together, but rather a set of an integrated sensors that are formed on a common substrate and used as a complete unit [Boeker, 2002]. As the field of applications has been developed, attention has moved towards the development of sensors specifically for use in arrays. Furthermore, almost all such arrays have been made up of a single sensor type [Gardner and Bartlett, 1999].

The advantages of the use of sensors in an array form are (1) technical conditioning, i.e. control of temperature stability, sample mass flow rate, etc. are simpler, (2) a more compact measuring chamber, i.e. a single measuring chamber is used by all sensors, and (3) better description of the measurand, i.e. the measurand can be described in a better way by a series of sensors (in form of a pattern) than if it were described by a single sensor. The quartz crystal microbalance sensor has been used in a numerous fields of application including gas mixture analysis [Abbas et al., 1999], detection of solvent vapors [Auge et al., 1995], detection of organic vapors [Hierlemann et al., 1995; Kim et al., 1997], detection of carbon dioxide (CO₂) [Gomes et al., 1995], discrimination of aromatic optical isomers [Ide et al., 1995], discrimination of odorants [Kasai et al., 2000], detection of mutagenic polycyclic compounds [Kurosawa et al., 1997], detection of organic pollutants in water [Lucklum et al., 1996], detection of L-glutamic acid [Liu et al., 1995], and discrimination of aromas from various Japanese sake [Nanto et al., 1995], etc.

ACKNOWLEDGEMENT

We wish to thank to the German Federal Ministry of Education and Research (BMBF) and the German Academic Exchange Service (DAAD) for the funding support.

REFERENCES

- Abbas, M. N., G. A. Moustafa, J. Mitrovics, W. Göpel. 1999. Multicomponent gas analysis of a mixture of chloroform, octane and toluene using a quartz crystal sensor array. *Analytica Chimica Acta* 393: 67-76.
- Abe, T and M. Esashi. 2000. One-chip multichannel quartz crystal microbalance (QCM) fabricated by deep RIE. *Sensors and Actuators A* 82: 139-143.
- Abumaizar, R. J., W. Kocher and E. H. Smith. 1998. Biofiltration of BTEX contaminated air streams using compost-activated carbon filter media. *Journal of Hazardous Materials* 60: 111-126.
- Ali, Z., W. T. O'Hare, T. Sarkodie-Gyan and B. J. Theaker. 1999. Gas sensing system using an array of coated quartz crystal microbalances with a fuzzy interference system. *Journal of Thermal Analysis and Calorimetry* Vol. 55: 371-381.
- Althainz, P., J. Goschnick, S. Ehrmann and H. J. Ache. 1996. Multisensor microsystem for contaminants in air. *Sensors and Actuators B* 33: 72-76.
- Anklam, E., M. Lipp, B. Radovic, E. Chiavaro and G. Palla. 1998. Characterisation of Italian vinegar by pyrolysis-mass spectrometry and a sensor device ("electronic nose"). *Food Chemistry* Vol. 61 No. 1/2 pp. 243-248.
- Annor-Frempong, I. E., G. R. Nute, D. J. Wood, F. W. Whittington and A. West. 1998. The measurement of the responses to different odour intensities of "boar taint" using a sensory panel and an electronic nose. *Meat Science* Vol. 50 No. 2 pp. 139-151.
- Auge, J., P. Hauptmann, J. Hartmann, S. Rösler and R. Lucklum. 1995. Versatile microcontrolled gas sensor array system using the quartz microbalance principle and pattern recognition methods. *Sensors and Actuators B* 26-27: 181-186.
- Baby, R. E., M. Cabezas and E. N. Walsöe de Reca. 2000. Electronic nose: a useful tool for monitoring environmental contamination. *Sensors and Actuators B* 69: 214-218.
- Bachinger, T., U. Riese, R. Eriksson and C.-F. Mandenius. 2000. Monitoring cellular state transitions in a production-scale CHO-cell process using an electronic nose. *Journal of Biotechnology* 76: 61-71.
- Bockreis, A. and J. Jager. 1999. Odour monitoring by the combination of sensors and neural networks. *Environmental Modelling & Software* 14: 421-426.
- Boeker, P, G. Horner and S. Roesler. 2000. Monolithic sensor array based on a quartz microbalance transducer with enhanced sensitivity for monitoring agricultural emissions. *Sensors and Actuators B* 70: 37-42.
- Boeker, P . 2002. *Die Objektivierung des Geruchseindrucks Messung und Modellierung*. Habilitation Manuscript. University of Bonn. Bonn, Germany.
- Bonanni, E. A. 1998. The Addition of Chemicals to Liquid to Control Odors. *In Odor and VOC Control Handbook*, ed. HJ Rafson, Ch.8, 8.2-8.17. McGraw Hill, New York, USA.
- Bourgeois, W. and R. M. Stuetz. 2000. Measuring wastewater quality using a sensor array: prospects for real-time monitoring. *Water Science and Technology* Vol. 41 No. 12 pp. 107-112.

- Brezmes, J., B. Ferreras, E. Llobet, X. Vilanova and X. Correig. 1997. Neural network based electronic nose for classification of aromatic species. *Analytica Chimica Acta* 348: 503-509.
- Buhlmann, K., J. Reinbold, K. Cammann, A. A. Shul'ga, C. Sundermeier, M. Knoll, A. Wierig and E. Weber. 1995. Clathrates as coating materials for dielectric transducers with regard to organic solvent vapour sensors. *Sensors and Actuators B* 26-27: 158-161.
- Burright, D. 1990. *Sampling & Analytical Methods: 2- Butanone*. Occupational Safety and Health Administration (OSHA), US Department of Labor. Salt Lake City, Utah, USA. Available at:
<http://www.osha-slc.gov/dts/sltc/methods/organic/org084/org084.htm>
- Cao, Z., H. G. Lin, B. F. Wang, D. Xu and R. Q. Yu. 1996. A perfume odour-sensing system using an array of piezoelectric crystal sensors with plasticized PVC coatings. *Fresenius Journal of Analytical Chemistry* 355: 194-199.
- Card, T. R. 1998. Fundamentals: Chemistry and characteristics of odors and VOCs. *In Odor and VOC Control Handbook*, ed. H. J. Rafson, Ch.2, 2.1-2.36. McGraw Hill, New York.
- Cattrall, R. W. 1997. *Chemical Sensors*. Oxford University Press. Oxford.
- Chambon, L., Germain, J. P., Pauly, A., Demarne, V., Grisel, A. 1999. A metallic oxide gas sensor array for a selective detection of the CO and NH₃ gases. *Sensors and Actuators B* 60: 138-147.
- Chang, P. and Shih, J. S. 2000. Multi-channel piezoelectric quartz crystal sensor for organic vapours. *Analytica Chimica Acta* 403: 39-48.
- Cheremisinoff, P. N. 1992. *Industrial Odour Control*. Butterworth Heinemann, Ltd. Oxford.
- Cho, K. S., M. Hirai and M. Shoda. 1992. Degradation of hydrogen sulphide by *Xanthomonas* sp. Strain DY44 isolated from peat. *Applied Environmental Microbiology* Vol. 58 No. 4 pp. 1193-1189.
- Chung, Y. C., C. Huang, C. P. Cheng and J. R. Pan. 2000. Biotreatment of H₂S- and NH₃-containing waste gases by co-immobilised cells biofilter. *Chemosphere* 41: 329-336.
- Corsi, R. L. and D. A. Olson. 1998. Emissions Model. *In Odor and VOC Control Handbook*, ed. H. J. Rafson, Ch.5, 5.11-5.25. McGraw Hill, New York.
- Cox, C. D., H-J. Woo and K. G. Robinson. 1998. *Water Science and Technology* Vol. 37 No.8 pp. 97-104.
- Cui L., M. J. Swann., A. Glidle, J. R. Barker and J. M. Cooper. 2000. Odour mapping using microresistor and piezo-electric sensor pairs. *Sensors and Actuators B* 66: 94-97.
- Deviny, J. S., M. A. Deshusses and T. S. Webster. 1999. *Biofiltration for Air Pollution Control*. CRC Press, Boca Raton, USA.
- Dickert, F. L., M. Reif and R. Sikorski. 2000^a. Chemical sensors for solvent vapors: Enthalpic and entropic contributions to host-guest interactions. *Journal of Molecular Modelling* 6: 446-451.
- Dickert, F. L., S. Landgraf and R. Sikorski. 2000^b. Host-guest chemistry and chemical sensors: FT-IR analysis and spectra simulation of CDCl₃ inclusion. *Journal of Molecular Modelling* 6: 491-497.
- Di Natale, C., A. Mantini, A. Macagnano, D. Antuzzi, R. Paolesse and A. D'Amico. 1999. Electronic nose analysis of urine samples containing blood. *Physiological Measurement* 20: 377-384.

- Di Natale, C., A. Macagnano, R. Paolesse, E. Tarizzo, A. Mantini and A. D'Amico. 2000. Human skin odor analysis by means of an electronic nose. *Sensors and Actuators B* 65: 216-219.
- Edwards, F. G. and Nirmalakhandan. 1996. Biological treatment of air stream contaminated with VOCs: an Overview. *Water Science and Technology* Vol. 34 No. 3-4 pp. 565-571
- Ehrmann, S., J. Jüngst, J. Goschnick and D. Everhard. 2000. Application of a gas sensor microarray to human breath analysis. *Sensors and Actuators B* 65: 247-249.
- Eklöv, T. and I. Lundström. 1999. Gas mixture analysis using a distributed chemical sensor system. *Sensors and Actuators B* 57: 274-282.
- EPA. 2000. Guide to Field Storage of Biosolids and Other Organic By-products Used in Agriculture and for Soil Resource Management. US-EPA
- EPA. 2001. Odour impacts and Odour emission control measures for intensive agriculture Final Report. R&D Report Series No. 14. European Community European Regional Development Fund & EPA.
- Gao, L., T. C. Keener, L. Zhuang and K. F. Siddiqui. 2001. A technical and economic comparison of biofiltration and wet chemical oxidation (scrubbing) for odor control at wastewater treatment plants. *Environmental Engineering and Policy* 2: 203-212.
- Gardner, J. W. and P. N Bartlett. 1996. Performance definition and standardization of electronic noses. *Sensors and Actuators B* 33: 60-67.
- Gardner, J. W. and P. N. Bartlett. 1999. *Electronic Noses Principles and Applications*. Oxford University Press. Oxford, UK.
- Gomes, M. T., A. C. Duarte and J. P. Oliveira. 1995. Detection of CO₂ using a quartz crystal microbalance. *Sensors and Actuators B* 26-27: 191-194.
- Göpel, W. 1998. Chemical imaging: I. Concepts and visions for electronic and bioelectronic noses. *Sensors and Actuators B* 52: 125-142.
- Göpel, W. and K.-D. Schierbaum. 1991. Definitions and Typical Examples. *In Sensors a Comprehensive Survey Vol. 2*, eds. Göpel, W, J. Hesse, J. N. Zemel. Ch.1, 2-27. VCH, Weinheim, Germany.
- Guadarrama, A., Fernandez, J. A., Iniguez, M., Souto, J., de Saja, J. A. 2000. Array of conducting polymer sensors for the characterisation of wine. *Analytica Chimica Acta* 411: 193-200.
- Gudladt, U. 2001. *Emissionsminderungspotentiale prozessintegrierter Maßnahmen bei der Kompostierung von Bioabfall*. Ph.D. diss., Faculty of Mathematics and Natural Sciences, University of Kiel. Kiel, Germany.
- Hansen, N. G. and K. Rindel. 2000. Bioscrubbing, an effective and economic solution to odour control at wastewater treatment plants. *Water Science and Technology* Vol. 41 No. 6 pp. 155-164.
- Hellwig, G. V. 1998. US Federal State Laws. *In Odor and VOC Control Handbook*, ed. H. J. Rafson. McGraw Hill, New York, USA.
- Herrmann, U., T. Jonischkeit, J. Bargon, U. Hahn, Q.-Y. Li, C. Schalley, E. Vogel and F. Voegtle. 2002. Monitoring apple flavour by use of quartz microbalance. *Analytical and Bioanalytical Chemistry* 372: 611-614.
- Hierlemann, A, U. Weimar, G. Kraus, M. Schweizer-Berberich and W. Göpel. 1995. Polymer-based sensor arrays and multicomponent analysis for the detection of hazardous organic vapours in the environment. *Sensors and Actuators B* 26-27: 126-134.

- Hu, H.-Y., M. Nozawa, K. Fujie, T. Makabe and K. Urano. 1996. Studies of microbial acclimation to hard chemicals on the basis of respiratory quinone profiles and kinetic analyses. *Water Science and Technology* Vol.34 No.5-6 pp. 249-256.
- Huber, C. V. 2002. Factors for achieving successful and cost effective odor abatement. In *Proc. of Odor and Noise Specialty Conference*, Atlanta, GA., February 21.
- Ide, J., T. Nakamoto and T. Moriizumi. 1995. Discrimination of aromatic optical isomers using quartz-resonator sensors. *Sensors and Actuators A* 49: 73-78.
- Janni, K., L. Jacobson, J. Bicudo, D. Schmidt, H. Guo and B. Koehler. 2000. Emissions, Measurement, Control, and Regulation. In *Proc. Livestock and Poultry Odor Workshop*, 29-31. Dept. of Biosystems and Agricultural Engineering University of Minnesota, USA.
- Jones, W. L., R. G. Mirpuri, S. Villaverde, Z. Lewandowski and A. B. Cunningham. 1997. The effect of bacterial injury on toluene degradation and respiration rates in vapor phase bioreactors. *Water Science and Technology* Vol. 36 No.1 pp. 85-92.
- Juteau, P., D. Rho, R. Larocque and A. LeDuy. 1999. Analysis of the relative abundance of different types of bacteria capable of toluene degradation in a compost biofilter. *Applied Microbiology and Biotechnology*. Vol. 52 Issue 6 pp. 863-868.
- Kasai, N., I. Sugimoto and M. Nakamura. 2000. Discrimination of odorants of definite concentrations by using plasma-organic-film-coated QCR sensors. *Sensors and Actuators B* 65: 114-119.
- Kim, J. M., S. Y. Yoo, H. K. Shin and Y. S. Kwon. 1997. Organic vapour detection by using QCM coated with polymer sensing materials. *Synthetic Metals* 85: 1423-1424.
- Koe, L. C. C. and F. Yang. 2000. A bioscrubber for hydrogen sulphide removal. *Water Science and Technology* Vol. 41 No. 6 pp. 141-145.
- Koul, S., Chandra, R., Dhawan, S. K. 2001. Conducting polyaniline composite: a reusable sensor material for aqueous ammonia. *Sensors and Actuators B* 75: 151-159.
- Kuroda, K., T. Osada, M. Yonaga, A. Kane Matu, T. Nitta, S. Mouri and T. Kojima. 1996. Emissions of malodorous compounds and greenhouse gases from composting swine faeces. *Bioresource Technology* 56: 265-271.
- Kurosawa, S., E. Tawara-Kondo and N. Kamo. 1997. Detection of mutagenic polycyclic compounds using a piezoelectric quartz crystal coated with plasma- polymerized phthalocyanine derivatives. *Analytica Chimica Acta* 337: 1-3.
- Kwon, T-H., Park, S-H., Ryu, J-Y, Choi, H-H. 1998. Zinc oxide thin film doped with Al₂O₃, TiO₂, and V₂O₅ as sensitive sensor for trimethylamine gas. *Sensors and Actuators B* 46: 75-79.
- LAI (*Länderausschuss für Immissionsschutz*). 2000. *Geruchsimmissions-Richtlinie* (GIRL – Odour Emissions Guidelines), Ministry of Environment, Environmental Planning, and Agriculture of the State Nordrhein-Westfalen, Germany.
- Liang, Y., X. Quan, J. Chen, J. S. Chung, J. Y. Sung, S. Chen, D. Sue and Y. Zhao. 2000. Long-term results of ammonia removal and transformation by biofiltration. *Journal of Hazardous Materials B* 80: 259-269.
- Liu, D., Y. Lai, L. Nie and S. Yao. 1995. Rapid detection of L-glutamic acid using a series-electrode piezoelectric quartz crystal sensor. *Analytica Chimica Acta* 313: 229-236.
- Lu, C., M.-R. Lin and J. Lin. 2000. Removal of acrylonitrile vapor from waste gases by a trickle-bed air biofilter. *Bioresource Technology* 75: 35-41.

- Lucklum, R., S. Rösler, J. Hartmann and P. Hauptmann. 1996. On-line detection of organic pollutants in water by thickness shear mode resonators. *Sensors and Actuators B* 35-36: 103-111.
- McIntyre, A. 2000. Application of dispersion modelling to odour assessment: a practical tool or a complex trap? *Water Science and Technology* Vol. 41 No.6 pp. 81-88.
- McNevin, D. and J. Barford. 2000. Biofiltration as an odour abatement strategy. *Biochemical Engineering Journal* 5: 231-242.
- Morvan, M., T. Talou, A. Gaset and J. F. Beziau. 2000. Electronic-noses systems for control quality applications in automotive industry. *Sensors and Actuators B* 69: 384-388.
- Nakamoto, T., Y. Isaka, T. Ishige and T. Moriizumi. 2000. Odour-sensing system using preconcentrator with variable temperature. *Sensors and Actuators B* 69: 58-62.
- Nanto, H., S. Tsubakino, M. Habara, K. Kondo, T. Morita, Y. Douguchi, H. Nakazumi and R. I. Waite. 1996. A novel chemical sensor using $\text{CH}_3\text{Si}(\text{OCH}_3)_3$ sol-gel thin film coated quartz resonator microbalance. *Sensors and Actuators B* 43: 312-316.
- Nanto, H., N. Dougami, T. Mukai, M. Habara, E. Kusano, A. Kinbara, T. Ogawa and T. Oyabu. 2000. A smart gas sensor using polymer-film-coated quartz resonator microbalance. *Sensors and Actuators B* 66: 16-18.
- Nieuwenhuizen, M. S. and A. Venema. 1991. Mass-sensitive devices. *In Sensors a Comprehensive Survey Vol. 2*, eds. Göpel, W., J. Hesse, J. N. Zemel, Ch.13, 647-680. VCH, Weinheim, Germany.
- Nieß, J., T. Hamacher, P. Schulze Lammers, E. Weber and P. Boeker. 2002. A miniaturized thermal desorption unit for chemical sensing below odor threshold. *Euroensors XVI*, Prague, CZ, September 15-18.
- van Noort D., R. Rani and C.-F. Mandenius. 2001. Improving the sensitivity of a quartz crystal microbalance for biosensing by using porous gold. *Mikrochimica Acta* 136: 49-53.
- Nurul Islam, A. K. M., K. Hanaki and T. Matsuo. 1998. Fate of dissolved odorous compounds in sewage treatment plants. *Water Science and Technology* Vol. 38 No. 3 pp. 337-344.
- O'Sullivan, C. K. and G. G. Guilbault. 1999. Review Commercial quartz crystal microbalances - theory and applications. *Biosensors & Bioelectronics* 14: 663-670.
- Otto, M. 1999. *Chemometrics. Statistics and Computer Application in Analytical Chemistry*. Wiley-VCH, Weinheim, Germany.
- Parvatiyar, M. G., R. Govind and D. F. Bishof. 1996. Biodegradation of Toluene in a membrane biofilter. *Journal of Membrane Science* 119: 17-24.
- Patkar, A. N. 1998. Hybrid Systems. *In Odor and VOC Control Handbook*, ed. Rafson, H. J. McGraw Hill, New York, USA.
- Pearce, T. C., S. S. Schiffman, H. T. Nagle and J. W. Gardner. 2002. *Handbook of Machine Olfaction Electronic Nose Technology*, Ch.1. Wiley-VCH. Weinheim, Germany.
- Peixoto, J. and Mota, M. 1998. Biodegradation of toluene in a trickling filter. *Bioprocess Engineering* 19: 393-397.
- Ping, W., T. Yi, X. Haibao and S. Farong. 1997. A novel method for diabetes diagnosis based on electronic noses. *Biosensors and Bioelectronics*. Vol. 12 No. 9-10 pp. 1031-1036.

- Romain, A.-C., Nicolas, J., Wiertz, V., Maternova, J., Andre, P.H. 2000. Use of a simple tin oxide sensor array to identify five malodours collected in the field. *Sensors and Actuators B* 62: 73-79.
- Rechenbach, T., U. Schramm, P. Boeker, G. Horner, C. E. O. Roesky, J. Trepte, S. Winter, R. Pollex, J. Bargon, E. Weber and P. Schulze Lammers. 1999. A humidity-independent ammonia sensor based on a quartz microbalance: a test under agricultural conditions. *Sensors and Actuators B* 57: 255-260.
- Rechenbach, T. 2000. *Grundlagen zur Entwicklung eines Sensor-Arrays auf Schwingquarzbasis für biogene Gase*. Ph.D. diss. Faculty of Mathematics and Natural Sciences, University of Bonn. Bonn, Germany.
- Sauerbrey, G. 1959. *Verwendung von Schwingquarzen zur Wägung dünner Schichten und zur Mikrowägung*. *Zeitschrift für Physik* 155: 206-222.
- Skladany, G. J., M. A. Deshusses, J. S. Devinny, A. P. Togna and T. S. Webster. 1998. Biofilters. In *Odor and VOC Control Handbook*, ed. Rafson, H. J. McGraw Hill, New York, USA.
- Smells Database. Modular-CHEM Consortium, Department of Chemistry, UC Berkeley USA. Available at: <http://mc2.cchem.berkeley.edu/Smells/>
- Smet, E., H. van Langenhove and I. de Bo. 1999. The emission of volatile compounds during the aerobic and the combined anaerobic/aerobic composting of biowaste. *Atmospheric Environment* 33: 1295-1303.
- Sorial, G. A., F. L. Smith, M. T. Suidan, P. Biswas and R. C. Brenner. 1997. Performance of peat biofilter: impact of the empty bed residence time, temperature and toluene loading. *Journal of Hazardous Materials* 53: 19-33.
- Sorial, G. A., F. L. Smith, M. T. Suidan, A. Pandit, P. Biswas and R. C. Brenner. 1998. Evaluation of trickle-bed air biofilter performance for styrene removal. *Water Resources* Vol. 32 No.5 pp. 1593-1603.
- Stella, R., J. N. Barisci, G. Serra, G. G. Wallace and D. D. Rossi. 2000. Characterisation of olive oil by an electronic nose based on conducting polymer sensors. *Sensors and Actuators B* 63: 1-9.
- Strike, D. J., M. G. H. Meijerink and M. Koudelka-Hep. 1999. Electronic noses - A mini review. *Fresenius Journal of Analytical Chemistry* 364: 499-505.
- Stuetz, R. M., G. Engin and R. A. Fenner. 1998. Sewage odour measurements using a sensory panel and an electronic nose. *Water Science and Technology*. Vol. 38 No.3 pp. 331-335.
- Stuetz, R. M., R. A. Fenner and G. Engin. 1999. Assessment of odours from sewage treatment works by an electronic nose, H₂S analysis and olfactometry. *Water Resources*. Vol.33 No.2 pp. 453-461.
- Stussi, E., Stella, R., De Rossi, D. 1997. Chemoresistive conducting polymer-based odour sensors: influence of thickness changes on their sensing properties. *Sensors and Actuators B* 43: 180 - 185.
- Tiquia, S. M., N. F. Y. Tam and I. J. Hodgkiss. 1996. Microbial activities during composting of spent pig-manure sawdust litter at different moisture contents. *Bioresource Technology* 55: 201-206.
- Ulmer, H., J. Mitrovics, G. Noetzel, U. Weimar and W. Göpel. 1997. Odours and flavours identified with hybrid modular sensor systems. *Sensors and Actuators B* 43: 24-33.

- Valsaraj, K. T. 1998. Emission Modeling – Meteorology, Topography, and Dispersion. *In Odor and VOC Control Handbook*, ed. Rafson, H. J., Ch.5, 5.1-5.10. McGraw Hill, New York.
- Van de Leur, R. H. M. and A. van der Waal. 1999. Gas and vapour detection using polypyrrole. *Synthetic Metals* 102: 1330-1331.
- Wallenfang, O. *Erstellung eines numerischen Modells zur zeitaufgelösten Prognose luftgetragener Gasausbreitung und deren experimentelle Verifikation*. Bonn, University of Bonn, Diss., 2002.
- Wang, X., Carey, W.P., Yee, S.S. 1995. Monolithic thin-film metal-oxide gas sensor arrays with application to monitoring of organic vapors. *Sensors and Actuators B* 28: 63 - 70.
- Weckhuysen, B., L. Vriens and H. Verachtert. 1994. Biotreatment of ammonia- and Butanal-containing waste gases. *Applied Microbiology and Biotechnology* Vol. 42 Issue 1 pp. 147-152.
- Weiß, T., K. D. Schierbaum, U. T. van Velzen, D. N. Reinhoudt and W. Göpel. 1995. Self-assembled monolayers of supramolecular compounds for chemical sensors. *Sensors and Actuators B* 26-27: 203-207.
- Williams, T. O. 1995. *In* Smet, E., H. van Langenhove, I. De Bo. 1999. The emission of volatile compounds during the aerobic and the combined anaerobic/aerobic composting of biowaste. *Atmospheric Environment* 33: 1295-1303.
- Wuebker, S.-M. and C. G. Friedrich. 1996. Reduction of biomass in a bioscrubber for waste gas treatment by limited supply of phosphate and potassium ions. *Applied Microbiology and Biotechnology* 46: 475-480.
- Yang, Y.-M., P.-Y. Yang and X.-R. Wang. 2000. Electronic nose based on SAWS array and its odor identification capability. *Sensors and Actuators B* 66: 167-170.
- Yeom, S. H. and Y. J. Yoo. 1999. Removal of benzene in a hybrid bioreactor. *Process Biochemistry* 34: 281-288.
- Yuwono, A. S., T. Hamacher, P. Boeker and P. Schulze Lammers. 2001. Odour pollution in the environment: Development of a measuring system. *In Proc. of International Conference on Tropical Agriculture*, p.56. Bonn, Germany, October 9-11.
- Yuwono, A. S., T. Hamacher, J. Nieß, P. Boeker and P. Schulze Lammers. 2002. Odour measuring system using a mass sensitive sensor array and its performance improvement. *In Proc. of the Second World Engineering Congress*, Kuching-Sarawak, Malaysia, July 21-25.
- Yuwono, A.S., Boeker, P. and Schulze Lammers, P. Detection of odour emissions from a composting facility using a QCM sensor array. *Analytical and Bioanalytical Chemistry* 375 (2003): 1045-1048.
- Zhang, Q. 2001. Odour emissions from confined swine production facilities. *In Proc. National Conference "Livestock Options for the Future"*, Winnipeg, Manitoba, Canada, June 25-27. Available at: <http://www.gov.mb.ca/agriculture/livestock/livestockopt/papers/zhang.pdf>
- Zhou, R., U. Weimar, K. D. Schierbaum, K. E. Geckeler and W. Göpel. 1995. Silicon-containing monomers, oligomers and polymers as sensitive coatings for the detection of organic solvent vapours. *Sensors and Actuators B* 26-27: 121-125.
- Zhu, X., M. J. Rihn, M. T. Suidan, B. J. Kim and B. R. Kim. 1996. The effect of nitrate on VOC removal in trickle-bed biofilters. *Water Science and Technology* Vol. 34 No. 3-4 pp. 573-581.

- Zhu, X., C. Alonso, M. T. Suidan, H. Cao, B. J. Kim and B. R. Kim. 1998. The effect of liquid phase on VOC removal in trickle-bed biofilters. *Water Science and Technology* Vol. 38 No. 3 pp. 315-322.
- Zondervan, C. , S. Muresan, H. G. de Jonge, E. U. T. van Velzen, C. Wilkinson, H. H. Nijhuis and T. Leguijt. 1999. Controlling maillard reactions in the heating process of blockmilk using an electronic nose. *Journal of Agricultural and Food Chemistry* 47: pp. 4746-4749.